

HEAT TORCH™



Shown with optional inlet & exhaust fittings

HT075

- Our Heat Torch™ 075 is a 0.75" diameter compact inline air heater providing moderate amounts of focused air. The Heat Torch™ 075 offers over twice the air flow capacity of the Heat Torch™ 050. The Heat Torch™ 075 can be mounted in either a horizontal or vertical position and includes several inlet and exhaust fittings options.
- Heat Torch™ 075 will meet requirements for air flow ranging from 1.3 to 25 SCFM with power of 100 watts to 1000 watts (in 100 watts increments).
- Maximum air input temperature is 250° F (121° C) with 1300° F (704° C) maximum output temperature.
- Applications for Heat Torch™ 075 include staking, curing, drying, heat shrinking, sterilization, and adhesive activation.

Wattage	Min. SCFM Req.
0.1kW	1.3
0.2kW	1.3
0.3kW	1.3
0.4kW	1.3
0.5kW	1.3
0.6kW	1.3
0.7kW	1.3
0.8kW	1.4
0.9kW	1.7
1.0kW	1.8

Airflow (SCFM)	Pressure Drop (psig)
1.3	0.10
2	0.20
3	0.45
4	0.80
6	1.8
8	3.2
10	5.0
15	11.3
20	20.0
25	31.3

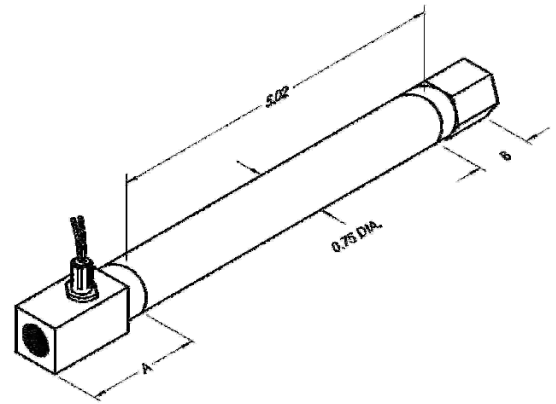

Wattage & Voltage Options

Mica Core (Max. Exhaust of 900° F):
120V, single phase, 0.4kW-.9kW
240V, single phase, 0.2kW-1.0kW

Ceramic Core (Max. Exhaust of 1300° F):
120V, single phase, 0.4kW-.9kW
240V, single phase, 0.2kW-1.0kW

Fitting Options

Inlet Fitting:
1/8F- 1/8" FNPT
1/4F- 1/4" FNPT
CB- Counterbore 1/2" O.D.

Exhaust Fitting:
1/4F- 1/4" FNPT
3/8F- 3/8" FNPT
NF- No Fitting
TE- 3/4" to 1/2" Reducing Adaptor

Other Options

Thermocouple Fitting
Thermocouple
Flexible Conduit

Inlet Fitting	Dim. A	Exhaust Fitting	Dim. B
1/8F	1.32	1/4F	0.85
1/4F	1.58	3/8F	0.85
CB	1.32	NF	0.04
		TE	0.16

Specifications

Category:	Inline Heaters, Process Heaters, Open Coil Heaters
Max. wattage:	1.0kW
Max. exhaust air temp.:	1300°F
Max. inlet air temp.:	250°F
(consult factory for higher inlet temp.)	
Max. SCFM:	25
Pressure Rating:	120 psig
Mounting:	Horizontal/Vertical
Leads:	20 gauge (12" long)
Heater Body:	Stainless Steel
Inlet Fitting:	Stainless Steel
Exhaust Fitting:	Stainless Steel



Part Number Key

HT075	400	120	1/8F	1/4F	TF1	(XXX)
Heat Torch 075	Wattage	Voltage	Inlet Fitting	Exhaust Fitting	Thermocouple Fitting	Modification

www.farnam-custom.com