

FINE series PURE

Bellows • Metal Diaphragm series



FUDF-916G-6.35

FUBFL-71-6.35

FPR-71-6.35

Safety & Clean Technology

Fujikin Incorporated

BELLOWS VALVE

SWITCH BELLOWS VALVE

BELLOWS NEEDLE VALVE

METAL DIAPHRAGM VALVE

BELLOWS VALVE

SWITCH BELLOWS VALVE

BELLOWS NEEDLE VALVE

METAL DIAPHRAGM VALVE

BELLOWS VALVE

SWITCH BELLOWS VALVE

Fujikin's Class 1 cleanrooms feature cutting-edge technology throughout, and must exceed the most rigorous standards for cleanliness. Products manufactured in this environment are therefore guaranteed to meet the most stringent requirements and to be of the highest quality worldwide.



INDEX

BELLOWS-METAL DIAPHRAGM series

Bellows

- Pneumatically-Actuated Bellows Valve3
- Pneumatically-Actuated High-Pressure Bellows Valve ...7
(High-Pressure Applications)
- Switch Bellows®11
(Quarter-Turn Switch Type)
- Bellows Valve15
(Round Handle)
- Bellows Needle Valve19
(Rough Needle)
(Flow Control Needle Valve with Micrometer)

Metal Diaphragm

- Metal Diaphragm Valve21
(Round Handle for High-Pressure Applications)

Options

- Additional Information.....25
- Comparison Chart26



Pneumatically-Actuated Bellows Valves

Stainless Steel 1MPa

The Fujikin pneumatically-actuated bellows valve is a compact valve designed for ultra-pure, flammable, or toxic fluid lines for all types of semiconductor equipment and facilities.

The Fujikin bellows valve is the most successful valve in the semiconductor industry due to its superior sealing performance, remarkable durability, compactness, ease of cleaning, and excellent purge characteristics.

Colored caps differentiate between normally-open (blue) and normally-closed (red) valves, thereby simplifying recognition.

The actuator features a unique rotation mechanism, allowing for actuation pressure to be supplied from any desired direction for both normally open and normally closed valves.

No external leakage due to rugged metal gasket seal.

Uniform bellows shape promotes highly effective purging and cleaning.

Standard disk packing material is PCTFE. High-Temperature / Polyimide / PFA disk packing materials are also available.

UP treatment for wetted surfaces is optionally available.

A wide variety of end-connections are available.

N.O. N.C.

0.34~0.69MPa TYPE N.C.

SPECIFICATIONS

Specification	Nominal Diameter	Maximum Operating Pressure	Fluid Temperature Range	Maximum Cv	Actuation Pressure	Actuator Port	End-Connections	Actuation Type
	6.35 (1/4")	1MPa 145 psi	-10~80 °C 14~176 °F	0.3	0.34~0.69MPa 48~70 psi	Rc 1/8"	F900 UJR Tube Stub	Normally Closed (NC) Normally Open (NO)
	9.52 (3/8")			0.8				
	12.7 (1/2")							

● All valves are helium leak tested. Vacuum method/results: External leakage: 5×10^{-12} Pa·m³/sec. Seat leakage: 5×10^{-12} Pa·m³/sec
 ● Demonstrated superior durability - over 5 million cycles (actual test results).

Materials	Part	Material
	Body	SUS316L
	Bellows	SUS316L
	Disk Packing	PCTFE
	Actuator	A5056

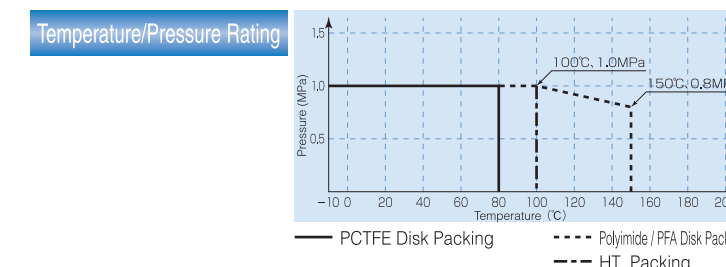

PART NUMBER DESIGNATION

Please use the part number designations below when placing an order.

FPR- -71 -6.35 - - -

A	B	C	D	E	F	G	H	I	J
FP : Normally open FPR : Normally closed	T B : Added only for 3-port valves	7 : UJR, UPG end-connection 9 : F900 end-connection 5 : Tube Stub end-connection*	1 : 1MPa maximum operating pressure	RS 2 : With proximity sensor* LS : With limit switch*	End-Connection Size 6.35 : 1/4" ^{OD} 9.52 : 3/8" ^{OD} 12.7 : 1/2" ^{OD} (UJR connections have a 9.52 port diameter)	BW : Butt weld*	Blank : Male UJR on both ends 2 : Female UJR on both ends 3 : UJR male inlet / Female UJR outlet	IN : Inconel bellows* PI : Polyimide disk packing* PA : PFA disk packing* HT : High-temperature PCTFE disk packing* BR : Female UJR with Purging*	UP : UP treatment* PS : Cr ₂ O ₃ treatment*

* Optional or made to order.

Actual shipped products may have additional designations (such as #A, #B) in the part number. These indicate production history and do not indicate a change in function or dimensions.



DIMENSIONS

Figure 1

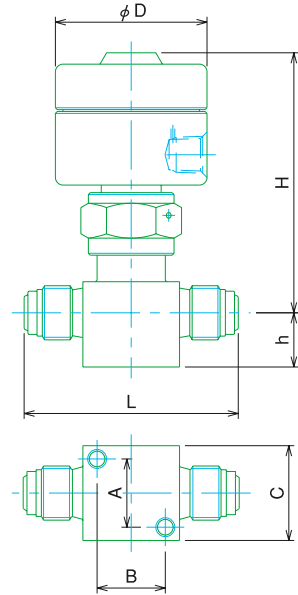

Figure 2

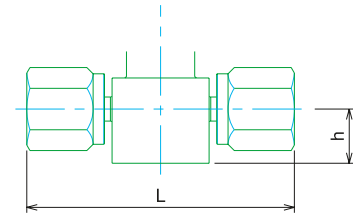

Figure 3

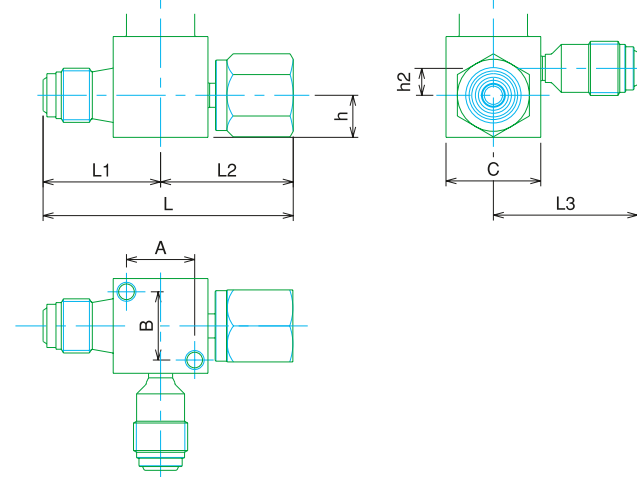

Figure 4

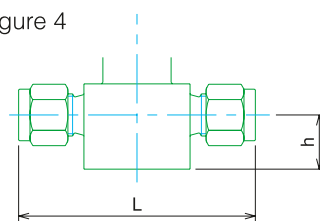
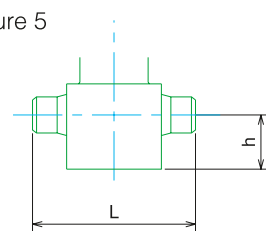

Figure 5



(Unit : mm)

Part Number	Figure	D	L	H	h	A	B	C	L1	L2	L3	h2
FP(R)-71-6.35	1	40	57.1	68.4	14.3	18	18	25				
FP(R)-71-6.35-2	2	40	70.6	68.4	14.3	18	18	25				
FP(R)-71-9.52	1	40	76.2	72.9	11.1	20.2	20.2	28				
FP(R)-71-9.52-2	2	40	83	72.9	12.7	20.2	20.2	28				
FP(R)-TB-71-6.35	3	40	65.7	74.7	11.1	18	18	25	31	34.7	38.1	7.1
FP(R)-TB-71-9.52×6.35	3	40	69.9	74.7	11.1	18	18	25	31.8	38.1	38.1	7.1
FP(R)-51-6.35	5	40	42.9	67.9	17.3	18	18	25				
FP(R)-51-9.52	5	40	57.1	72.9	12.7	20.2	20.2	28				
FP(R)-51-12.7	5	40	57.1	27.9	12.7	20.2	20.2	28				
FP(R)-91-6.35	4	40	63.5	68.4	14.3	18	18	25				
FP(R)-91-9.52	4	40	80	72.9	12.7	20.2	20.2	28				
FP(R)-91-12.7	4	40	85	62.9	12.7	20.2	20.2	28				

See Figure 1 for dimension keys not shown in other Figures.

OPTIONS

Block Valve

FBL-9.52×6.35-2B3

Block valve design allows for

- Compact tubing arrangement
- Dead-space free configuration

In addition to our standard 2-actuator, 3-port block, we also offer custom block valves according to customer's specifications.



FPR-71RS2-6.35

Proximity Sensor

An electrical signal confirms open or closed position of valve. The non-contact proximity sensor offers unsurpassed safety.

Limit Switch

FPR-71LS-6.35

An electrical signal confirms open or closed position of valve.



FBT-70-6.35-3B4-BR-EAJ

Multi-Mini

Smaller size actuator (Ø30 mm) makes it easy to create even more compact block valve configurations.

Other

Angle-type and 3/4" ^{OD} (Ø19.05 mm connection size) size can be made according to customer specifications.

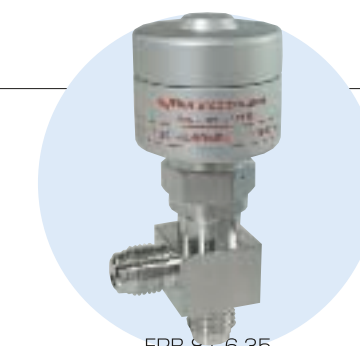

FPR-81-6.35



FPR-91-19.05

Photos are samples of each product type.



Pneumatically-Actuated High Pressure Bellows Valve

Stainless Steel 16.2 MPa

The Fujikin pneumatically-actuated high-pressure bellows valve is a compact valve designed for ultra-pure, flammable, or toxic fluid lines for all types of semiconductor equipment and facilities.

The Fujikin bellows valve is the most successful valve in the semiconductor industry due to its superior sealing performance, remarkable durability, compactness, ease of cleaning, and excellent purge characteristics.

Colored caps differentiate between normally-open (blue) and normally-closed (red) valves, thereby simplifying recognition.

The actuator features a unique rotation mechanism, allowing for actuation pressure to be supplied from any desired direction for both normally open and normally closed valves.

No external leakage due to rugged metal gasket seal.

Uniform bellows shape promotes highly effective purging and cleaning.

Standard disk packing material is PCTFE. Polyimide disk packing material is also available.

UP treatment for wetted surfaces is optionally available.

A wide variety of end-connections are available.

N.O. N.C.

0.39~0.59MPa

SPECIFICATIONS

Specification	Nominal Diameter	Maximum Operating Pressure	Fluid Temperature Range	Maximum Cv	Actuation Pressure	Actuator Port	End-Connections	Actuation Type
6.35 (1/4")	16.2MPa	-10~80 °C	0.3	0.39~0.59MPa	Rc 1/8"	F900 UJR Tube Stub	Normally Closed (NC) Normally Open (NO)	
9.52 (3/8")	2,350 psi	14~176 °F		56~85 psi				

● All valves are helium leak tested. Vacuum method/results: External leakage: 5×10^{-12} Pa·m³/sec. Seat leakage: 5×10^{-12} Pa·m³/sec
 ● Demonstrated superior durability - over 400,000 cycles (actual test results).

Materials	Part	Material
	Body	SUS316L
	Bellows	Inconel 718
	Disk Packing	PCTFE
	Actuator	A5056

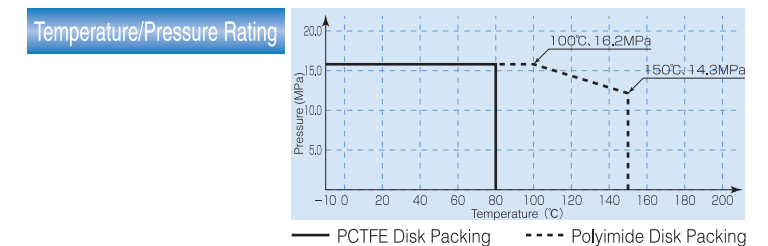

PART NUMBER DESIGNATION

Please use the part number designations below when placing an order.

FPR-UBF[]-716[]-6.35[]-[]-[]-[]

A	B	C	D	E	F	G	H	I	J	K
F P : Normally open F P R : Normally closed	U B F : Stainless steel bellows valve	T B : Added only for 3-port valves	7 : UJR, UPG end-connection 9 : F900 end-connection 5 : Tube Stub end-connection*	1 6 : 16.2 MPa maximum operating pressure	L S : With limit switch*	End-Connection Size 6.35 : 1/4" ^{OD} 9.52 : 3/8" ^{OD}	BW : Butt weld*	Blank : Male UJR on both ends 2 : Female UJR on both ends	P I : Polyimide disk packing* B R : Female UJR with Purging*	U P : UP treatment*

* Optional or made to order.
 Actual shipped products may have additional designations (such as #A, #B) in the part number. These indicate production history and do not indicate a change in function or dimensions.



DIMENSIONS

Figure 1

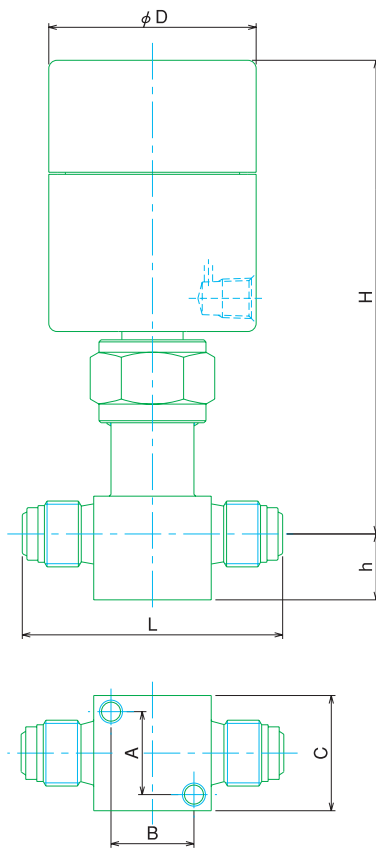

Figure 2

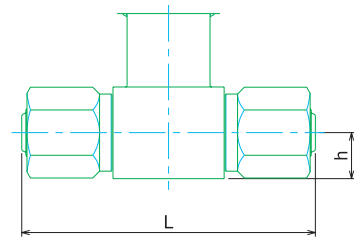

Figure 3

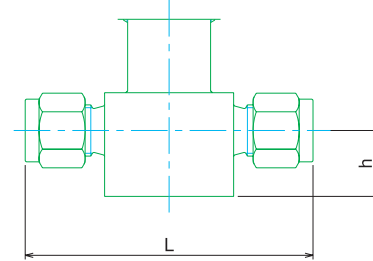

Figure 4

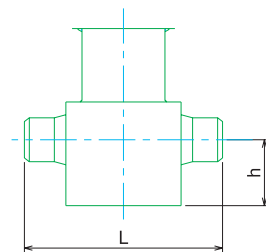
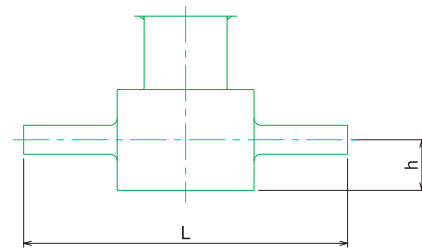

Figure 5



(Unit : mm)

Part Number	Figure	D	L	H	h	A	B	C
FP(R)-UBF-716-6.35	1	50	58.7	115 (122)	11.1	18	18	25
FP(R)-UBF-716-9.52	2	50	70.6	115 (122)	11.1	18	18	25
FP(R)-UBF-716-6.35-2	1	50	76.2	115 (122)	11.1	18	18	25
FP(R)-UBF-716-9.52-2	2	50	83	115 (122)	11.1	18	18	25
FP(R)-UBF-516-6.35	4	50	44.5	115 (122)	11.1	18	18	25
FP(R)-UBF-516-6.35BW	5	50	71	115 (122)	11.1	18	18	25
FP(R)-UBF-916-6.35	3	50	63.5	115 (122)	11.1	18	18	25
FP(R)-UBF-916-9.52	3	50	66	115 (122)	11.1	18	18	25

() Brackets indicate dimensions for normally-closed valves. See Figure 1 for dimension keys not shown in other Figures.

OPTIONS

Limit Switch

FPR-UBF-716LS-6.35

An electrical signal confirms open or closed position of valve.



Third-Party Certifications

Valves may be tested and certified by a third-party testing agency to verify conformance to published standards, such as high-pressure gas service specifications, and so on. Contact Fujikin for further details.





Switch Bellows® (Quarter Turn Switch Type)

Stainless Steel 1MPa

The Fujikin Switch Bellows® valve is a compact valve designed for ultra-pure, flammable, or toxic fluid lines for all types of semiconductor equipment and facilities.

The Fujikin Switch Bellows® valve is the most successful valve in the semiconductor industry due to its superior sealing performance, remarkable durability, compactness, ease of cleaning, and excellent purge characteristics.

Valve open or closed position is easily visible at a glance.

Open Closed

One touch, snap type quarter turn operation makes it easy to operate the valve. A spring assures even and consistent seat force to provide positive shutoff, and also extends the seat life dramatically.

No external leakage due to rugged metal gasket seal.

Uniform bellows shape promotes highly effective purging and cleaning.

Standard disk packing material is PCTFE. High-Temperature / Polyimide / PFA disk packing materials are also available.

UP treatment for wetted surfaces is optionally available.

A wide variety of end-connections are available.

SPECIFICATIONS

Specification	Nominal Diameter	Maximum Operating Pressure	Fluid Temperature Range	Maximum Cv	End-Connections
	6.35 (1/4")	1MPa 145 psi	-10~80 °C 14~176 °F	0.3	F900 UJR Tube Stub
	9.52 (3/8")			0.8	
	12.7 (1/2")			0.8	

● All valves are helium leak tested. Vacuum method/results: External leakage: 5×10^{-12} Pa·m³/sec. Seat leakage: 5×10^{-12} Pa·m³/sec
 ● Demonstrated superior durability - over 20,000 cycles (actual test results).

Materials	Part	Material
	Body	SUS316L
	Bellows	SUS316L
	Disk Packing	PCTFE
	Handle	Nylon 6

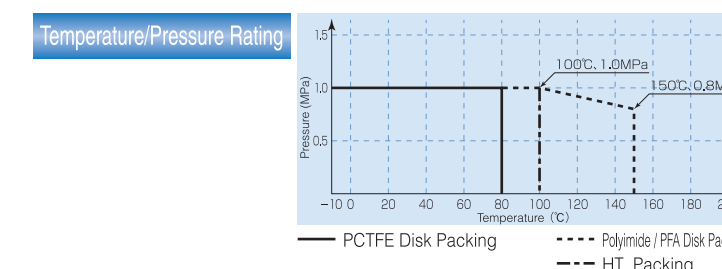

PART NUMBER DESIGNATION

Please use the part number designations below when placing an order.

FUBF L [] - 71 - 6.35 [] - [] - []

A	B	C	D	E	F	G	H	I	J
Stainless steel bellows valve	L : Quarter turn open/closed handle	T B : Added only for 3-port valves	7 : UJR, UPG end-connection 9 : F900 end-connection 5 : Tube Stub end-connection* 0 : F900 end-connection, angle type 8 : UJR end-connections, angle type	1 : 1MPa maximum operating pressure	End-Connection Size 6.35 : 1/4" ^{OD} 9.52 : 3/8" ^{OD} 12.7 : 1/2" ^{OD} (UJR connections have a 9.52 port diameter)	BW : Butt weld*	Blank : Male UJR on both ends 2 : Female UJR on both ends 3 : UJR male inlet / Female UJR outlet	P I : Polyimide disk packing* P A : PFA disk packing* H T : High-temperature PCTFE disk packing* B R : Female UJR with Purering*	U P : UP treatment*

* Optional or made to order.

Actual shipped products may have additional designations (such as #A, #B) in the part number. These indicate production history and do not indicate a change in function or dimensions.



DIMENSIONS

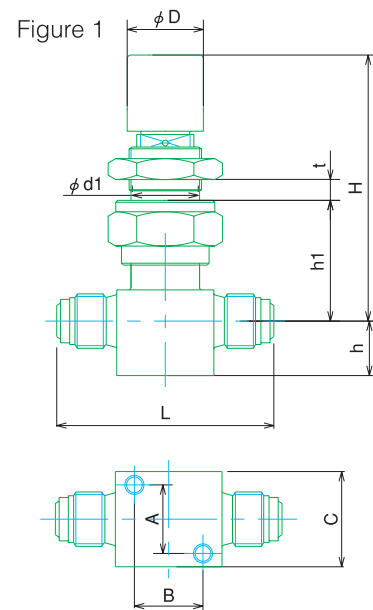

Figure 2

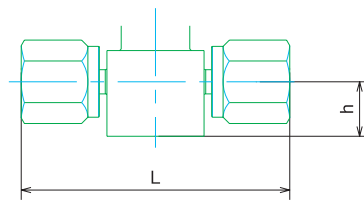

Figure 3

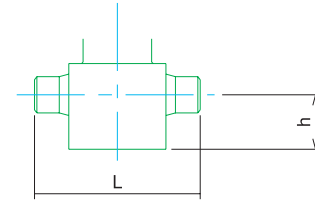

Figure 4

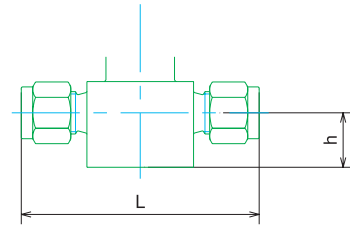
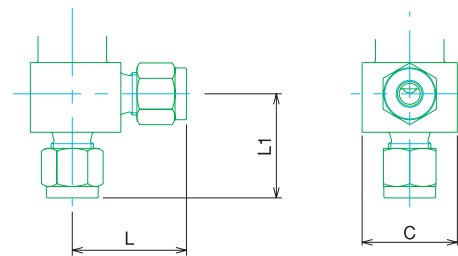

Figure 5



OPTIONS

Handle Colors

GT-HL-FUBFL-*

A letter in place of "*" indicates handle color:
Blue=B, Green=G, Yellow=Y, Red=R

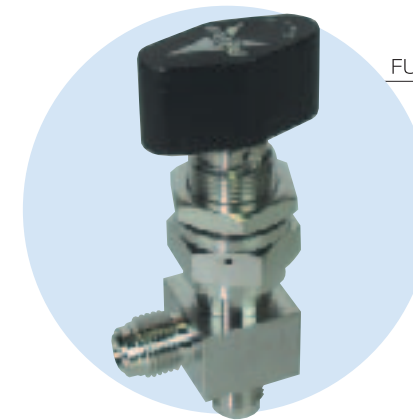
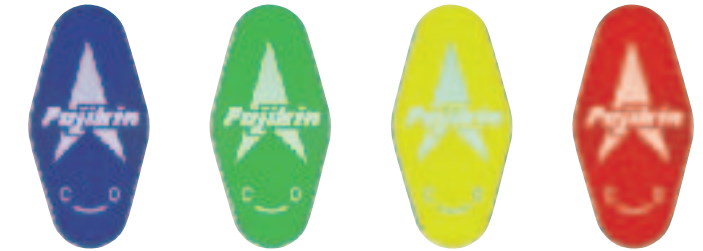

FUBFL-81-6.35

Other

Angle-type can be made according to customer specifications.

(Unit : mm)

Part Number	Figure	D	L	H	h	t	h1	d1	A	B	C	L1
FUBFL-71-6.35	1	20	57.1	71.5	14.3	8.5	31.5	19.5	18	18	25	
FUBFL-71-6.35-2	2	20	70.6	71.5	14.3	8.5	31.5	19.5	18	18	25	
FUBFL-71-9.52	1	20	76.2	76.3	11.1	8.5	36	19.5	20.2	20.2	28	
FUBFL-71-9.52-2	2	20	83	76.3	12.7	8.5	36	19.5	20.2	20.2	28	
FUBFL-51-6.35	3	20	42.9	71.5	14.3	8.5	31.5	19.5	18	18	25	
FUBFL-51-9.52	3	20	57.1	76.3	12.7	8.5	36	19.5	20.2	20.2	28	
FUBFL-51-12.7	3	20	57.1	76.3	12.7	8.5	36	19.5	20.2	20.2	28	
FUBFL-91-6.35	4	20	63.5	71.5	14.3	8.5	31.5	19.5	18	18	25	
FUBFL-91-9.52	4	20	80	76.3	12.7	8.5	36	19.5	20.2	20.2	28	
FUBFL-91-12.7	4	20	85	76.3	12.7	8.5	36	19.5	20.2	20.2	28	
FUBFL-01-6.35	5	20	32	71.5		8.5	31.5	19.5			25	32
FUBFL-01-9.52	5	20	40	76.3		8.5	36	19.5			28	40
FUBFL-01-12.7	5	20	42.5	76.3		8.5	36	19.5			28	42.5

See Figure 1 for dimension keys not shown in other Figures.



Round Handle Bellows Valve

Stainless Steel 1MPa

The Fujikin Round Handle Bellows valve is a compact valve designed for ultra-pure, flammable, or toxic fluid lines for all types of semiconductor equipment and facilities.

The Fujikin Round Handle Bellows valve is the most successful valve in the semiconductor industry due to its superior sealing performance, remarkable durability, compactness, ease of cleaning, and excellent purge characteristics.

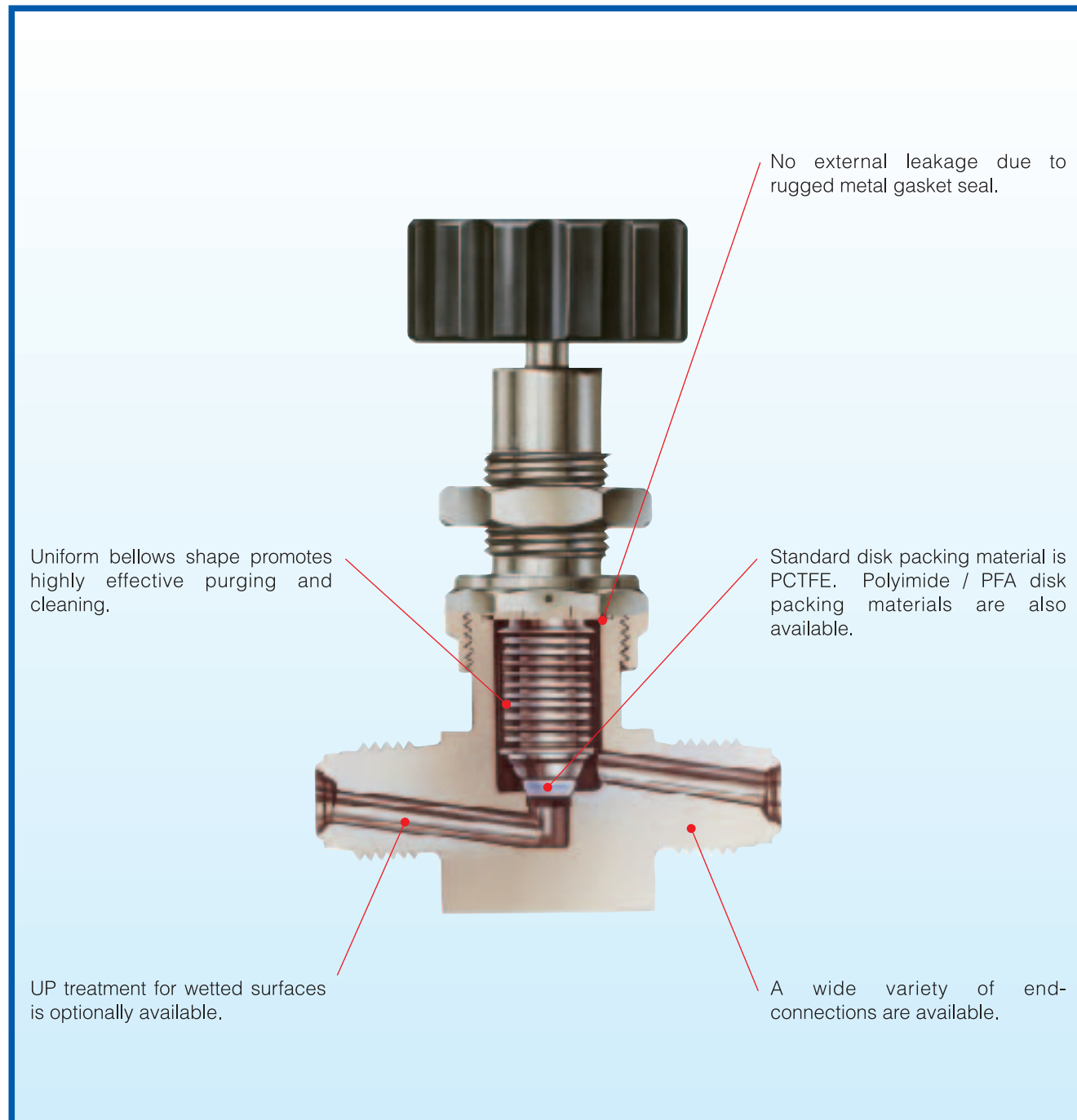

SPECIFICATIONS

Specification	Nominal Diameter	Maximum Operating Pressure	Fluid Temperature Range	Maximum Cv	End-Connections
	6.35 (1/4")	1MPa 145 psi	-10~80 °C 14~176 °F	0.3	F900 UJR Tube Stub
	9.52 (3/8")			0.8	
	12.7 (1/2")			0.8	

● All valves are helium leak tested. Vacuum method/results: External leakage: <math> < 5 \times 10^{-12} \text{ Pa} \cdot \text{m}^3/\text{sec}</math>. Seat leakage: <math> < 5 \times 10^{-12} \text{ Pa} \cdot \text{m}^3/\text{sec}</math>
 ● Demonstrated superior durability - over 20,000 cycles (actual test results).

Materials	Part	Material
	Body	SUS316L
	Bellows	SUS316L
	Disk Packing	PCTFE
	Handle	A5056

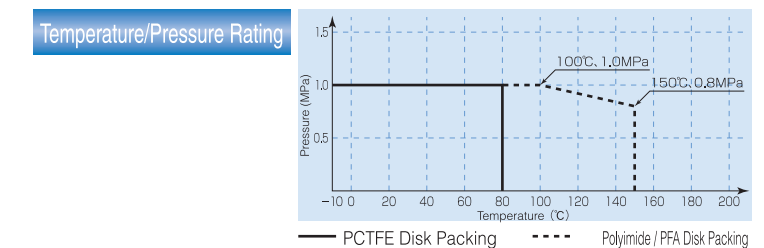

PART NUMBER DESIGNATION

Please use the part number designations below when placing an order.

FUB--71-6.35---

A	B	C	D	E	F	G	H	I
Stainless steel bellows valve	T B : Added only for 3-port valves	7 : UJR, UPG end-connection 9 : F900 end-connection 5 : Tube Stub end-connection* 0 : F900 end-connection, angle type 8 : UJR end-connections, angle type	1 : 1MPa maximum operating pressure	End-Connection Size 6.35 : 1/4" OD 9.52 : 3/8" OD 12.7 : 1/2" OD (UJR connections have a 9.52 port diameter)	BW : Butt weld*	Blank : Male UJR on both ends 2 : Female UJR on both ends 3 : UJR male inlet / Female UJR outlet	P I : Polyimide disk packing* P A : PFA disk packing* B R : Female UJR with Purering*	UP : UP treatment*

* Optional or made to order.

Actual shipped products may have additional designations (such as #A, #B) in the part number. These indicate production history and do not indicate a change in function or dimensions.



DIMENSIONS

Figure 1

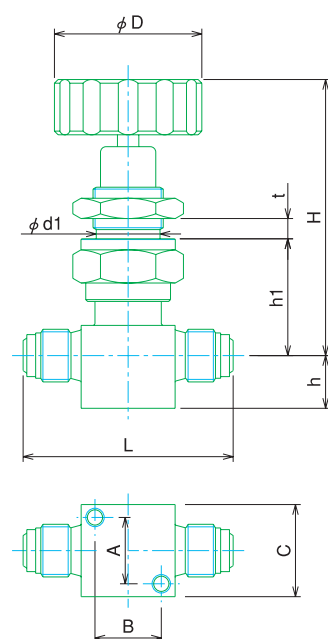

Figure 2

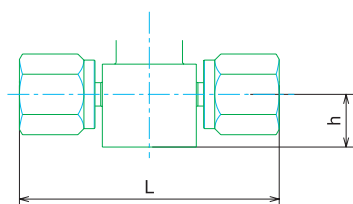

Figure 3

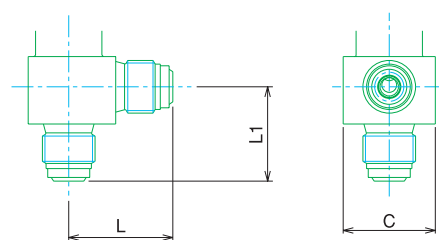

Figure 4

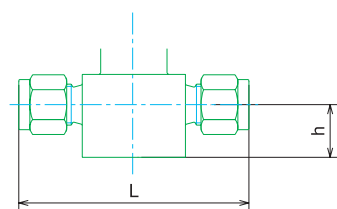
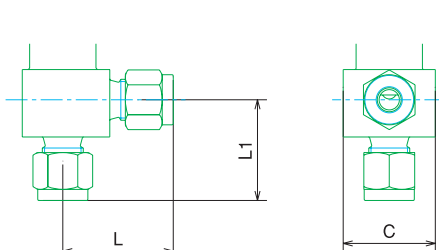

Figure 5



(Unit : mm)

Part Number	Figure	D	L	H	h	t	h1	d1	A	B	C	L1
FUB-71-6.35	1	40	57.1	78.5	14.3	9.5	31.5	19.5	18	18	25	
FUB-71-6.35-2	2	40	70.6	78.5	14.3	9.5	31.5	19.5	18	18	25	
FUB-71-9.52	1	40	76.2	83	11.1	9.5	36	19.5	20.2	20.2	28	
FUB-71-9.52-2	2	40	83	83	12.7	9.5	35	19.5	20.2	20.2	28	
FUB-81-6.35	3	40	28.5	78.5		9.5	31.5	19.5			25	25.8
FUB-81-9.52	3	40	38.1	84		9.5	37	19.5			28	35
FUB-91-6.35	4	40	63.5	78.5	14.3	9.5	31.5	19.5	18	18	25	
FUB-91-9.52	4	40	80	83	12.7	9.5	36	19.5	20.2	20.2	28	
FUB-91-12.7	4	40	85	83	12.7	9.5	36	19.5	20.2	20.2	28	
FUB-01-6.35	5	40	32	78.5		9.5	31.5	19.5			25	32
FUB-01-9.52	5	40	40	83		9.5	36	19.5			28	40
FUB-01-12.7	5	40	42.5	83		9.5	36	19.5			28	42.5

See Figure 1 for dimension keys not shown in other Figures.

OPTIONS

Other

Angle-type and 3/4" OD (Ø19.05 mm connection size) size can be made according to customer specifications.

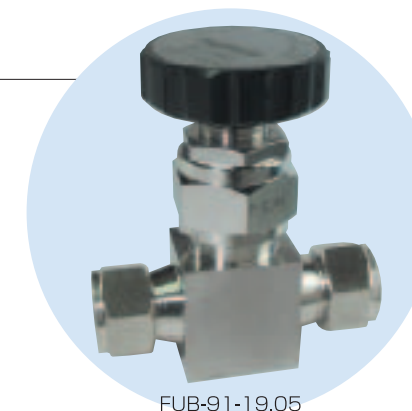

FUB-91-19.05



FUB-81-6.35

Photos are samples of each product type.



Needle Bellows Valve

Stainless Steel 1 MPa

The Fujikin Needle Bellows valve is a compact valve designed for ultra-pure, flammable, or toxic fluid lines for all types of semiconductor equipment and facilities.

The Fujikin Needle Bellows valve is the most successful valve in the semiconductor industry due to its superior sealing performance, remarkable durability, compactness, ease of cleaning, and excellent purge characteristics.

Rough Needle Valve

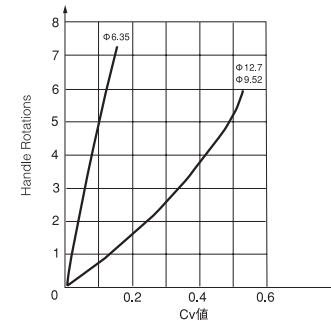
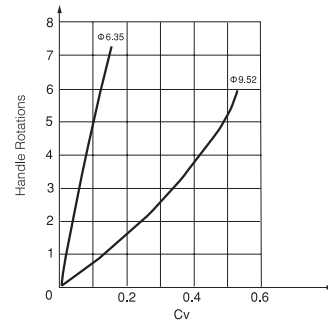

Flow Control Needle Valve with Micrometer

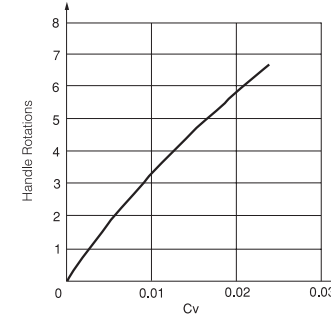
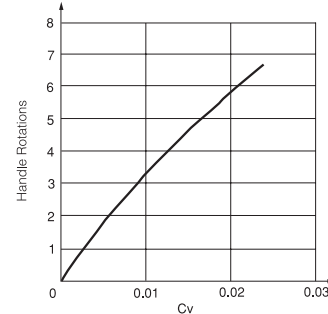

UP Treatment is optionally available.

SPECIFICATIONS

Specification	Nominal Diameter	Maximum Operating Pressure	Fluid Temperature Range	Orifice Diameter	Maximum Cv	End-Connections
	6.35 (1/4")	1MPa 145 psi	-10~80 °C 14~176 °F	5	0.132	F900 UJR
	9.52 (3/8")			1.8	0.02	
	12.7 (1/2")			8	0.452	

●All valves are helium leak tested. Vacuum method/results: External leakage: 5×10^{-12} Pa·m³/sec.

Materials	Part	Material
	Body	SUS316L
	Bellows	SUS316L
	Bonnet Gasket*	PCTFE
	Handle	A5056

*Metal seal is optionally available.

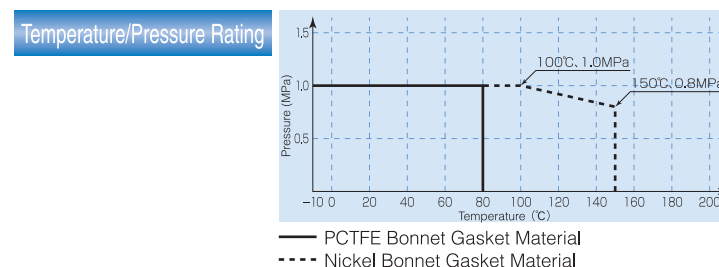

Needle Bellows Valve

PART NUMBER DESIGNATION

Please use the part number designations below when placing an order.

FUBFN-[]-71[]-6.35[]-[]-[]

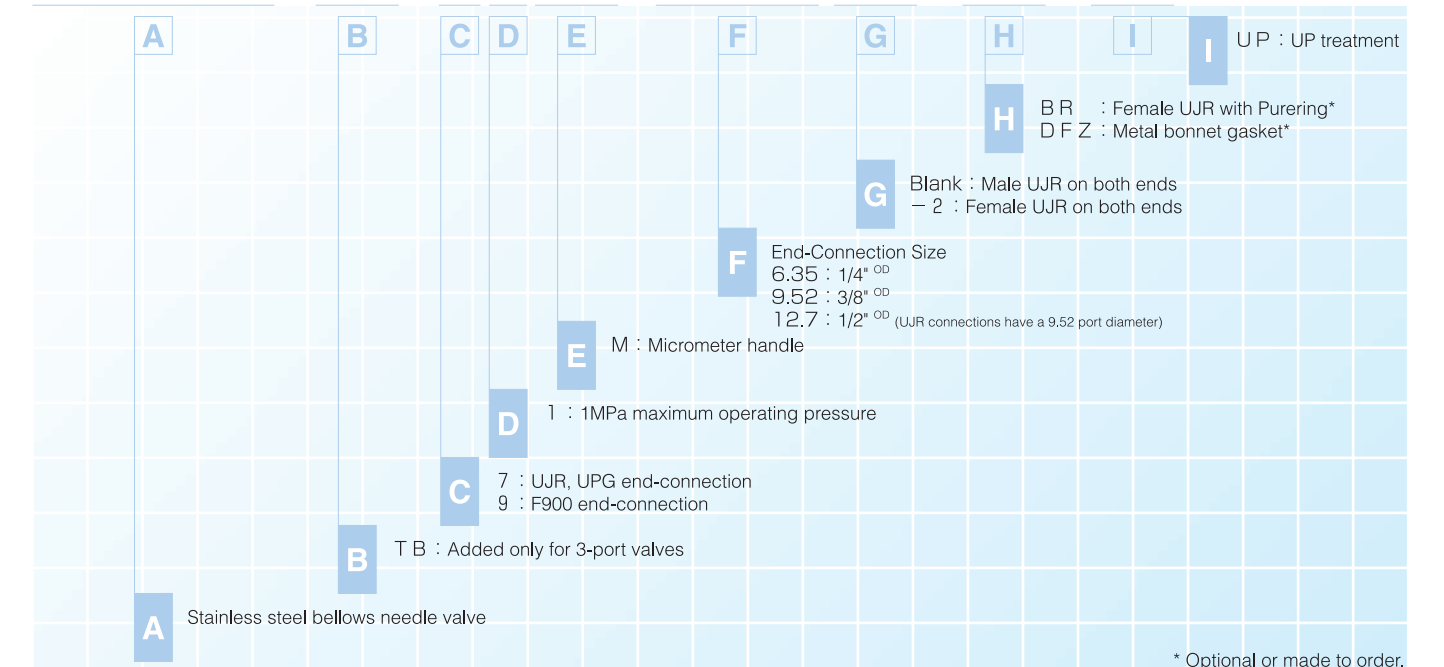

* Optional or made to order.

Actual shipped products may have additional designations (such as #A, #B) in the part number. These indicate production history and do not indicate a change in function or dimensions.

DIMENSIONS

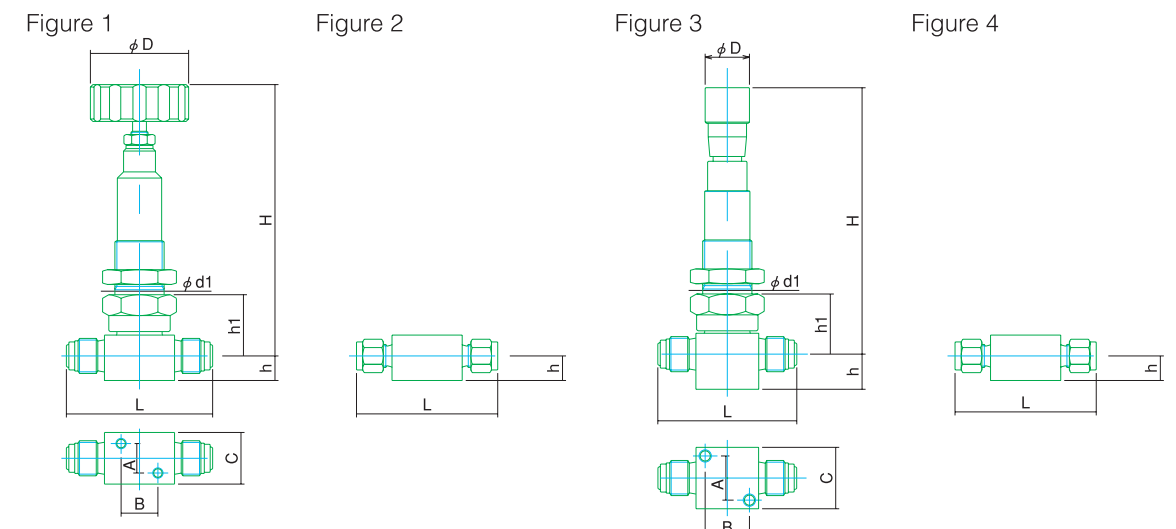

Part Number	Figure	D	L	H	h	h1	d1	A	B	C
FUBFN-71-6.35	1	40	65	112	13	25	20.5	12	15	21
FUBFN-71-9.52	1	50	72	120	17	29.5	20.5	15	20	26
FUBFN-91-6.35	2	40	63	111	10	24	20.5	12	15	21
FUBFN-91-9.52	2	50	71	117.5	12	27	20.5	15	20	26
FUBFN-91-12.7	2	50	81	118.5	14	28	20.5	15	20	26
FUBFN-71M-6.35	3	18	57	108.5	14.3	24.5	20.5	18	18	25
FUBFN-91M-6.35	4	18	64	108.5	9.5	24.5	20.5	12	15	21

(Unit : mm)

() Brackets indicate dimensions for normally closed valves. See Figure 1 for dimension keys not shown in other Figures.



Metal Diaphragm Bellows Valve

Stainless Steel 16.2 MPa

The Fujikin metal diaphragm bellows valve is a compact valve designed for ultra-pure, flammable, or toxic fluid lines for all types of semiconductor equipment and facilities.

The Fujikin metal diaphragm bellows valve offers superior sealing performance, remarkable durability, and compactness.

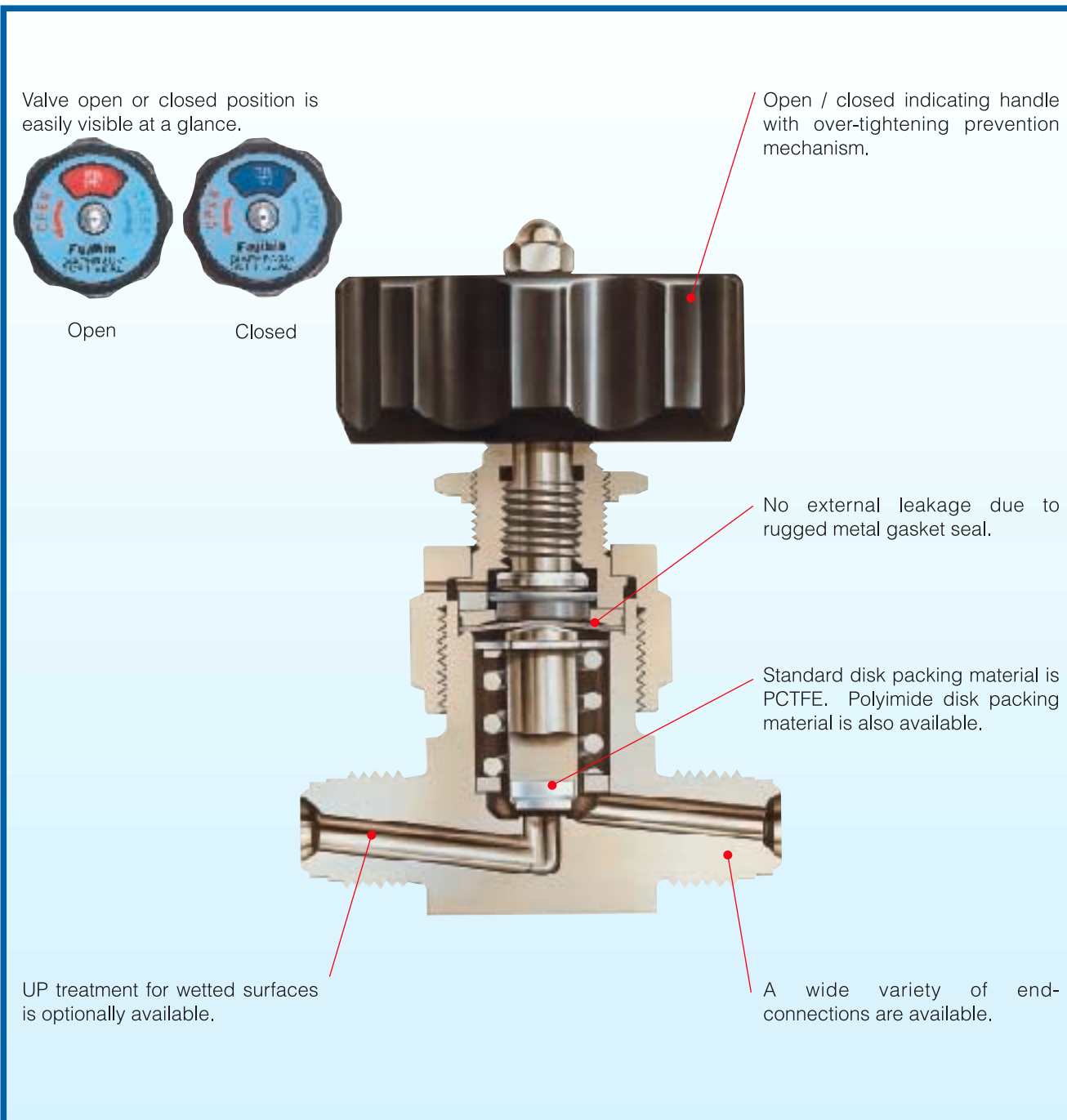

SPECIFICATIONS

Specification	Nominal Diameter	Maximum Operating Pressure	Fluid Temperature Range	Maximum Cv	End-Connections
	6.35 (1/4")	16.2MPa 2,350 psi	-10~80 °C 14~176 °F	0.3	F900 UJR Tube Stub
	9.52 (3/8")				
	12.7 (1/2")				

● All valves are helium leak tested. Vacuum method/results: External leakage: $< 5 \times 10^{-12}$ Pa·m³/sec. Seat leakage: $< 5 \times 10^{-12}$ Pa·m³/sec
 ● Demonstrated superior durability - over 9,000 cycles (actual test results).
 ※ The differential pressure between the inlet and outlet should be less than 10.3 MPa (1,500 psid). If the differential pressure exceeds this value, a valve with a higher rating must be specified.

Materials	Part	Material	Temperature/Pressure Rating
	Body	SUS316L	
	Diaphragm	Inconel 718	
	Stem	SUS316L	
	Disk Packing	PCTFE	
	Spring	SUS316WPB	

PART NUMBER DESIGNATION

Please use the part number designations below when placing an order.

FUDF [] - 7 1 6 G - 6.35 [] - [] - [] - []

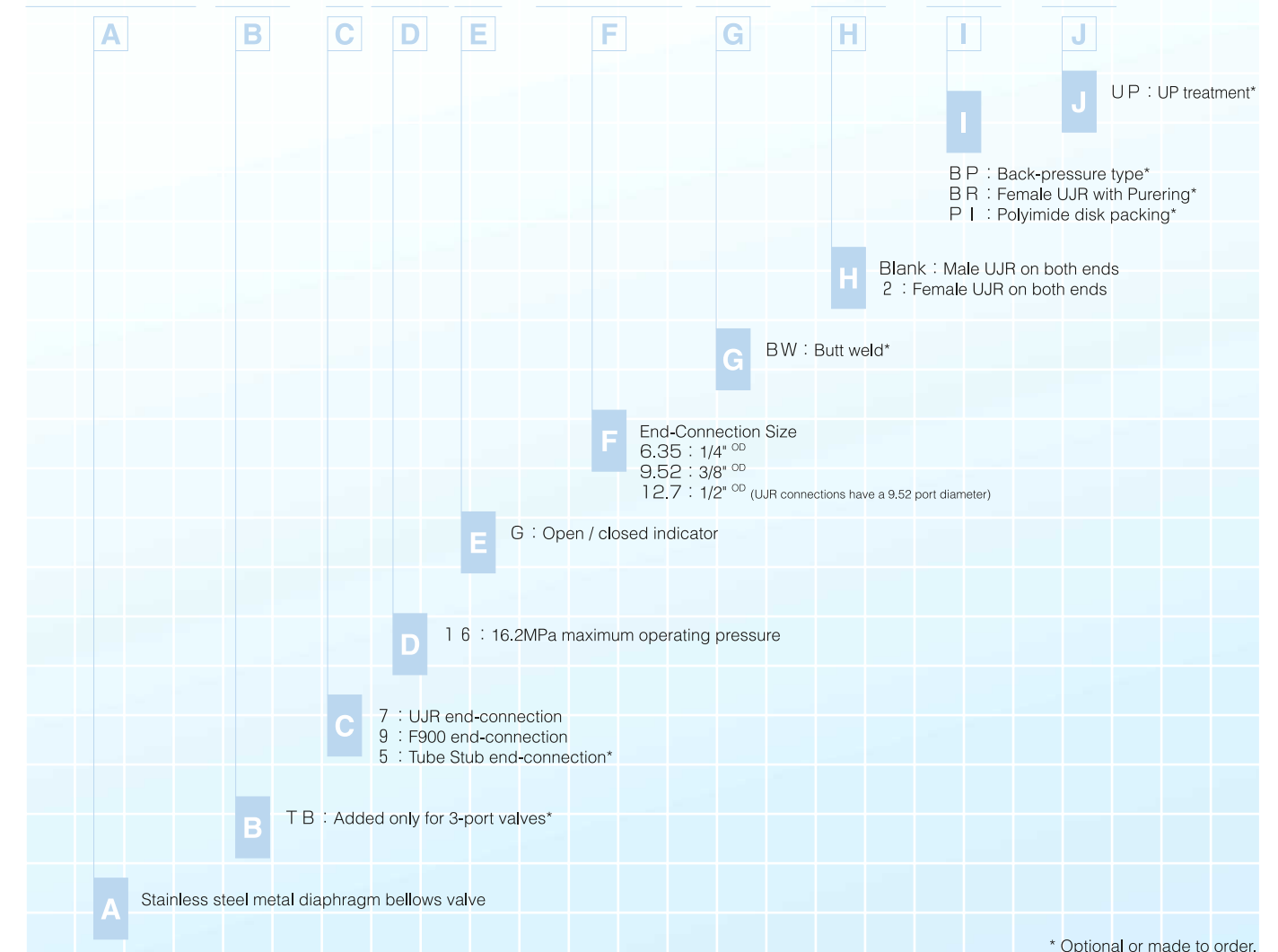

* Optional or made to order.

Actual shipped products may have additional designations (such as #A, #B) in the part number. These indicate production history and do not indicate a change in function or dimensions.



DIMENSIONS

Figure 1

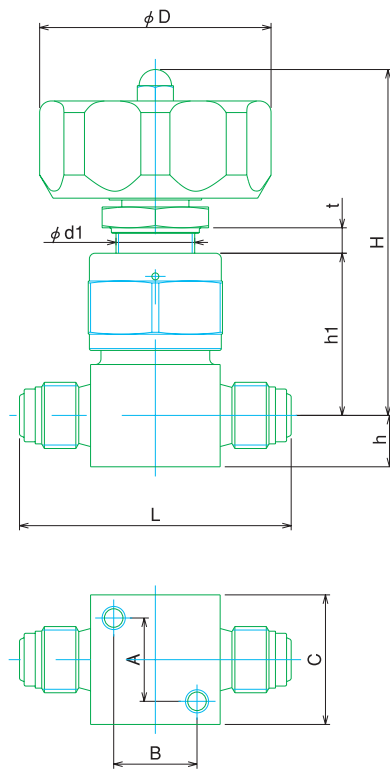

Figure 2

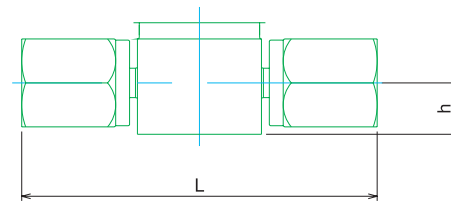

Figure 3

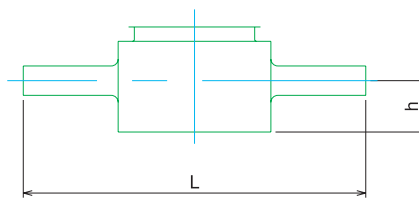

Figure 4

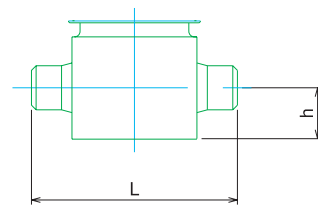
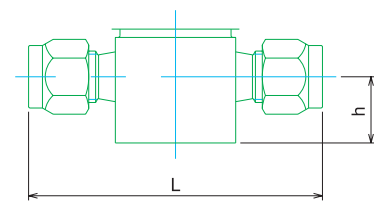

Figure 5



(Unit : mm)

Part Number	Figure	D	L	H	h	t	h1	d1	A	B	C
FUDF-716G-6.35	1	50	58.7	75.3	11.1	5	35	19.5	18	18	28
FUDF-716G-6.35-2	2	50	70.6	78.8	11.1	5	35	19.5	18	18	28
FUDF-716G-9.52	1	50	76.2	76.3	11.1	5	36	19.5	18	18	28
FUDF-716G-952-2	2	50	83	78.8	11.1	5	36	19.5	18	18	28
FUDF-516G-6.35	4	50	44.5	75.3	11.1	5	35	19.5	18	18	28
FUDF-516G-9.52	4	50	46	75.3	11.1	5	36	19.5	18	18	28
FUDF-516G-6.35BW	3	50	74	78.8	11.1	5	35	19.5	18	18	28
FUDF-516G-9.52BW	3	50	74	78.8	11.1	5	36	19.5	18	18	28
FUDF-516G-12.7BW	3	50	74	78.8	11.1	5	36	19.5	18	18	28
FUDF-916G-6.35	5	50	63.5	75.3	11.1	5	35	19.5	18	18	28
FUDF-916G-9.52	5	50	66	75.3	11.1	5	36	19.5	18	18	28
FUDF-916G-12.7	5	50	73	75.3	11.1	5	36	19.5	18	18	28

See Figure 1 for dimension keys not shown in other Figures.

OPTIONS

Handle Colors

GT-HL-FUDF-*

A letter in place of " * " indicates handle color:
Blue=B, Green=G, Yellow=Y, Red=R



FUDF-716G-6.35-BP

Back Pressure Type (High Pressure)

If the back pressure is over 10.3 MPa (1,500 psi), standard valves may not be able to open successfully. Therefore under high back pressure conditions, a stronger internal spring is installed to ensure proper valve operation.

Third-Party Certifications

Valves may be tested and certified by a third-party testing agency to verify conformance to published standards, such as high-pressure gas service specifications, and so on. Contact Fujikin for further details.



FUDF-725-6.35-HP(24.5MPa type)

Ultra-High Pressure

Valves able to handle even higher pressures (3,500 psi) than our standard series are optionally available by contacting Fujikin.

Photos are samples of each product type.



ADDITIONAL INFORMATION

● Inner Surface Treatment

Products with ULTRA EXTREME PURE (UP) Special Internal Treatment

By utilizing a special polishing technology to first remove work-affected and work-hardened layers from the metal surfaces, UP treated products attain an exceedingly pure metal surface having an extremely uniform passivated film. The surface roughness is kept below 0.7 mm Ry, with an average roughness being 0.1mm or less. Additionally, final cleaning is performed in a Class 1 cleanroom to completely remove particles and impurities, and to assure a thoroughly clean product.

The UP treatment is compatible with Hastelloy(R) and other corrosion resistant materials.

● Disk Packing Materials

PCTFE (polytetrafluoroethylene)

Standard seat material on bellows series and metal diaphragm series products.

PI (polyimide), PA (PFA)

Recommended option for non-standard temperatures and fluids.

● Body and Bellows Materials

Hastelloy®

For services that require exceptional corrosion resistance, Hastelloy C-22(R) bodies and diaphragms may be specified as an optional material.

Inconel

Inconel 718 bellows may be specified if high-cycle operation is demanded of a valve.

● Proximity Sensors and Limit Switches

When open or closed position verification is required on pneumatically actuated valves, proximity sensors or limit switches that output an electrical signal to an external unit are optionally available. Valves with a limit switch may be substituted for proximity sensor valves.

● Handle Colors

Handles may be specified in a wide variety of optional colors.

COMPARISON CHART

		Bellows					Metal Diaphragm
		Pneumatically Actuated Bellows Valves	Pneumatically Actuated High-Pressure Bellows Valves	Switch Bellows	Round Handle Bellows Halve	Needle Bellows Valve	Metal Diaphragm Valve
Pressure Type	High-Pressure	—	●	—	—	—	●
	High-Pressure Gas Cert.	—	▲	—	—	—	▲
Nominal Diameter	6.35	●	●	●	●	●	●
	9.52	●	●	●	●	※2	●
	12.7	●※1	—	●※1	●※1	●※1※2	●※1
End-Connection	UJR	●	●	●	●	●	●
	UJR w/Purering	▲	▲	▲	▲	▲	▲
	F900	●	●	●	●	●	●
	Butt Weld	▲	▲	▲	▲	▲	▲
	Socket Weld	▲	▲	▲	▲	▲	▲
Inner Surface Treatment	BA	●	●	●	●	●	●
	UP	▲	▲	▲	▲	▲	▲
Body Material	SUS316L	●	●	●	●	●	●
	Hastelloy®	▲	▲	▲	▲	▲	▲
Bellows Material	SUS316L	●	—	●	●	●	—
	Inconel 718	▲	●	—	—	—	—
Diaphragm Material	Inconel 718	—	—	—	—	—	●
Disk Packing Material	PCTFE	●	●	●	●	—	●
	PI	▲	▲	▲	▲	—	▲
	PA	▲	—	▲	▲	—	—
Other	Proximity Sensor	▲	—	—	—	—	—
	Limit Switch	▲	▲	—	—	—	—
	Handle Color	—	—	▲	—	—	▲

● : Installed as standard ▲ : Installed as option
 ※1 : Installed only when F900 is selected as end-connection type.
 ※2 : Standard only on rough needle valve type



Fujikin Incorporated
Fujikin of America, Inc.
Fujikin Deutschland GmbH.

Head quarters:

Kita-Hankyu Bldg., 4-8, Shibata1-chome, Kita-ku, Osaka 530-0012, Japan
 Phone: (81) 6-6372-7141 (Switch Board Number)
 Fax: (81) 6-6375-0697

Tokyo Head Office:

3-6, Nihonbashi 2-chome, Chuoku, Tokyo 103-0027, Japan
 Phone: (81) 3-3273-0301 (Switch Board Number)
 Fax: (81) 3-3273-0901

Overseas Operations Division:

Tokyo Office:

3-6, Nihonbashi 2-chome, Chuoku, Tokyo 103-0027, Japan
 Phone: (81) 3-3273-0301 (Switch Board Number)
 Fax: (81) 3-3273-0901

Osaka Office:

Kita-Hankyu Bldg., 4-8, Shibata1-chome, Kita-ku, Osaka 530-0012, Japan
 Phone: (81) 6-6372-7141 (Switch Board Number)
 Fax: (81) 6-6375-0697

U.S.A. New Jersey Office:

4 Alsan Way, Little Ferry, NJ 07643, U.S.A.
 Phone: (1) 201-641-1119
 Fax: (1) 201-641-1137

U.S.A. West Office:

Parkway Plaza 4677 Old Ironsides Dr. #100, Santa Clara, CA 95054, U.S.A.
 Phone: (1) 408-980-8269
 Fax: (1) 408-980-0572

U.S.A. Austin Office:

2028E, Ben White Blvd, Suite320 Austin, Texas 78741, U.S.A.
 Phone: (1) 512-912-9095
 Fax: (1) 512-912-8095

U.S.A. Oregon Office:

One World Trade Center, Suite 1100 121SW Salmon Street, Portland, OR 97204, U.S.A.
 Phone: (1) 503-471-1340
 Fax: (1) 503-471-1341

Dusseldorf Office:

Leopold strasse 9, 40211 Dusseldorf, Germany.
 Phone: (49) 211-350458/459
 Fax: (49) 211-363990

Main Plant with Stocking & Distribution Center:

3-9-21, Nagata, Higashi-Osaka 577-0015, Japan
 Phone: (81) 6-6787-2201
 Fax: (81) 6-6787-4541

IMPORTANT NOTICE:

The product data in this catalogue was obtained under specific test conditions that may vary substantially from actual site conditions and / or customer needs.

Each purchaser or other end-user of fujikin products must rely solely on its system design engineer(s) when selecting Fujikin products for a particular system, and when determining the suitability of any system in which a Fujikin products is to be installed.

FUJIKIN SHALL BEAR NO LIABILITY AS TO PRODUCT SELECTION CRITERIA OR DECISIONS, NOR SHALL FUJIKIN BELIEABLE AS TO ANY PRODUCT WHICH HAS BEEN DAMAGED, INCLUDING DIRECT, SPECIAL, OR CONSEQUENTIAL DAMAGES (INCLUDING BUT NOT LIMITED TO LOST PROFITS OR INCOME), BY MISUSE, IMPROPER HANDLING OR ACCIDENT, OR SERVICED OR MODIFIED BY ANYONE OTHER THAN FUJIKIN, OR SUBJECTED TO USE INVOLVING CONDITIONS, OR COMBINATIONS OF CONDITIONS, THAT IS NOT COMPATIBLE WITH THAT PARTICULAR FUJIKIN PRODUCT.

OUR TRADE MARK

- **AFMO** ● **Fujikin**
- **CARP** ● 

Fujikin Main Products

Stainless Steel Forgings, Stainless Steel Castings, Brass Forgings, Steel Forgings, Alkes®, Corrosion Resistant Aiuminum Forgings, Gun metal, Hastelloy Products, Zirconium Products, Tantalium Products, Titanium Products, Fujibloy Products, Plastic Products, Fine Ceramic Products, Other Special Metals, New Metal and Material Products.

—Valves—

- Various Types of Super Valves
- Various Types of Needle Valves(domestic patents×6)
- Block valve for every extra-high pressure
- QS valve® (international patent×7countries)
- Compact valves
- Various miniature valves
- Diaphragm type "MINI" control valves
- Soler old valves (domestic patent×3)
- Various Ball valves
- Various joints (domestic patent)

—Precision Machinery and tools—

- Atomic valve unit, joints etc. (domestic patent)
- Valve unit, joints etc. for the development of the universe (domestic patent)
- Valves unit, joints etc. for the development of the ocean (domestic patent)
- Valves unit, joints etc. for the development of the electronic machinery and tools (domestic patent)
- Valves unit, joints etc. for the development of the related machinery and tools to medical treatment.

—Unit · Apparatuses—

(example)

- Fuji-Tepler®, seal tape automatic winder (domestic patent)
- Provider power unit(domestic patent)
- Air Trap FAT®, PA-30B(international patent)
- Every Dry® (international patent)
- Sealless® finished product (domestic patent) (Sampling rack)
- Device for the collection of water in the can (Sampling rack)
- Chemical vapour doping system
- Anodic oxidation coating system
- Tester for valves, joints
- Medical treatment appliances
- High pressure gas apparatus
- Air computer (patented)
- Airtronics® (Hydraulic electronics controlling system)
- Contronics® (Hydraulic automatic control system)

—Special Products—

- Designing and manufacturing of Special Valves, Cocks, Joints, etc.

—Overseas Tie-up Products—

- UNTECH Hand Shrink Guns (technical tie-up products with West Germany)
- SAMUMAT automatic shrink wrapping machine (technical tie-up products with West Germany)
- Positioner (technical tie-up products with U.S.A)
- Hydraulic technic oil pressure aprpratus (technical tie-up products with West Germany)
- LEGRIX LF3000-one touch fitting (sales tie-up products with France)
- Glass fiber ball valves (sales tie-up products with the U.S.A)

—Products and Services—

- General piping components
- General service