

vacuum

SOLUTION

There is always something to do with vacuum tech in life.



04

SECTION CONTENTS

FITTING SERIES

General Information	4-I		
Pipe Wall Thickness in mm	4-II	90° Elbows with Tangents	4-2
Pipe Wall Thickness in in.	4-III	45° Elbows	4-3
Tube Wall Thickness in mm	4-IV	45° Elbows with Tangents	4-3
Tube Wall Thickness in in.	4-V	Tees	4-4
ASTM A269 Tubing Pressure Ratings	4-VI	4-Way Crosses	4-4
ASTM A312 Pipe Pressure Ratings	4-IX	Unequal Tees	4-5
Corrosion Resistance Guide	4-XI	Unequal 4-Ways Crosses	4-6
Conical Reducers	4-1	Five-Way Crosses	4-7
90° Elbows	4-2	Six-Way Crosses	4-7

General Information

Feature

- HTC tube fittings are convenient "building block" components. They offer great flexibility in the design and construction of high and ultra-high vacuum system.
- There are two type of bellows of HTC's products, or flexible metal hoses. "Flexible hoses" have concertina walls made by pressurizing a thin-wall tube, they can be bent but not be compressed. The other type is "Flexible bellows connections", this type can bent and compressed. When possible, design the system so that the bellows make only a single bend or curve. Multiple bends concentrate stress at minimum radius points, reducing life expectancy during flexing or vibration. An elbow on one or both ends will usually eliminate multiple bends. It is difficult to make a short bellows fit between parallel flange faces that are not coaxial.

Specifications

- Flanges : 304 S.S. (Other material available upon request)
- Fittings : 304 S.S. (Other material available upon request)
- Flexible hoses : 304 S.S.
- Flexible bellows connections : 316Ti, 321 S.S., 316L S.S., 316 S.S., 304 S.S.
- Htc tube fitting are made from welded pipe or tube.
- Larger or special size available upon request.
- Seamless pipe or tube are available upon request.

Applications

- Piping system.

Tube and Pipe O.D. Designator

Tube		Pipe (ANSI B36.19)		Pipe (JIS G3459)		IDF		3A		ISO		DIN (DIN11850)	
Nom.Size	O.D.	Nom.Size	O.D.	Nom.Size	O.D.	Nom.Size	O.D.	Nom.Size	O.D.	Nom.Size	O.D.	Nom.Size	O.D.
1/8	3.18	1/8	10.29	6A	10.5								
3/16	4.76	3/16											
1/4	6.35	1/4	13.72	8A	13.8								
5/16	7.94	5/16											
3/8	9.53	3/8	17.15	10A	17.3					12		DN10	12
1/2	12.7	1/2	21.34	15A	21.7					17.2		15	18
5/8	15.88	5/8											
3/4	19.05	3/4	26.67	20A	27.2					21.3		20	22
7/8	22.23	7/8											
1	25.4	1	33.4	25A	34	1	25.4	1	25.4	25		25	28
1 1/4	31.8	1 1/4	42.16	32A	42.7	1 1/4	31.8			33.7		32	34
1 1/2	38.1	1 1/2	48.26	40A	48.6	1 1/2	38.1	1 1/2	38.1	38		40	40
										40			
2	50.8	2	60.33	50A	60.5	2	50.8	2	50.8	51		50	52
2 1/2	63.5	2 1/2	73.03	65A	76.3	2 1/2	63.5	2 1/2	63.5	63.5		65	70
										70			
3	76.2	3	88.9	80A	89.1	3	76.3	3	76.2	76.1		80	85
3 1/2	88.9	3 1/2	101.6	90A	101.6	3 1/2	89.1			88.9			
4	101.6	4	114.3	100A	114.3	4	101.6	4	101.6	101.6		100	104
	114.3									114.3			
5	127	5	141.3	125A	139.8							125	129
	139.8									139.7			
6	152.4	6	168.3	150A	165.2							150	154
	165.1									168.3			
8	203.2	8	219.1	200A	216.3					219.1			

JISG3459 : Stainless Steel Pipes (Sch10)

IDF : International Daily Federation

3A : 3-A Sanitary Standards (International Association of Milk, Food and Environment Sanitariums, U.S Public Health Service)

ISO : International Organization for Standardization

DIN : Deutsches Institut für Normung (Germany DIN 11850)

Pipe Schedules (Metric Units)

NOMINAL WALL THICKNESS IN MILLIMETRES

Nominal Pipe Size In Inches	Outside Diameter In Millimetres	Sched 5	Sched 10	Sched 20	Sched 30	Standard	Sched 40	Sched 60	XS Extra Strong	Sched 80	Sched 100	Sched 120	Sched 140	Sched 160	XXS Double strong
1/8	10.29	0.89	1.24			1.73	1.73		2.41	2.41					
1/4	13.7	1.24	1.65			2.24	2.24		3.02	3.02					
3/8	17.1	1.24	1.65			2.31	2.31		3.20	3.20					
1/2	21.3	1.65	2.11			2.77	2.77		3.73	3.73				4.75	7.46
3/4	26.7	1.65	2.11			2.87	2.87		3.91	3.91				5.53	7.82
1	33.4	1.65	2.77			3.38	3.38		4.55	4.55				6.35	9.09
1 1/4	42.2	1.65	2.77			3.56	3.56		4.85	4.85				6.35	9.70
1 1/2	48.3	1.65	2.77			3.68	3.68		5.08	5.08				7.13	10.16
2	60.3	1.65	2.77			3.91	3.91		5.54	5.54				8.71	11.07
2 1/2	73.0	2.11	3.05			5.16	5.16		7.01	7.01				9.53	14.02
3	88.9	2.11	3.05			5.49	5.49		7.62	7.62				11.10	15.24
3 1/2	101.6	2.11	3.05			5.74	5.74		8.08	8.08					16.15
4	114.3	2.11	3.05			6.02	6.02		8.56	8.56		11.10		13.48	17.12
5	141.3	2.77	3.40			6.55	6.55		9.53	9.53		12.70		15.87	19.05
6	168.3	2.77	3.40			7.11	7.11		10.97	10.97		14.27		18.23	21.95
8	219.1	2.77	3.76	6.35	7.04	8.18	8.18	10.31	12.70	12.70	15.06	18.23	20.62	23.01	22.23
10	273.1	3.40	4.19	6.35	7.79	9.27	9.27	12.70	12.70	15.06	18.23	21.41	25.40	28.57	
12	323.9	4.19	4.57	6.35	8.38	9.53	10.31	14.27	12.70	17.45	21.41	25.40	28.57	33.32	
14	355.6		6.35	7.92	9.53	9.53	11.12	15.06	12.70	19.05	23.80	27.76	31.75	35.71	
16	406.4		6.35	7.92	9.53	9.53	12.70	16.66	12.70	21.41	26.19	30.93	36.52	40.46	
18	457.2		6.35	7.92	11.10	9.53	14.27	19.05	12.70	23.80	29.36	34.92	39.67	45.24	
20	508.0		6.35	9.53	12.70	9.53	15.06	20.62	12.70	26.19	32.51	38.10	44.45	49.99	
22	558.8		6.35			9.53			12.70						
24	609.6		6.35	9.53	14.27	9.53	17.45	24.59	12.70	30.94	38.89	46.02	52.37	59.51	
26	660.4					9.53			12.70						
30	762.0		7.925	12.7		9.53			12.70						
34	863.6					9.53			12.70						
36	914.4					9.53			12.70						

04 CHAPTER FITTING SERIES

NOMINAL WALL THICKNESS IN INCHES

Nominal Pipe Size In Inches	Outside Diameter In Inches	Sched 5	Sched 10	Sched 20	Sched 30	Standard	Sched 40	Sched 60	XS Extra Strong	Sched 80	Sched 100	Sched 120	Sched 140	Sched 160	XXS Double strong
1/8	0.405	0.035	0.049			0.068	0.068		0.095	0.095					
1/4	0.540	0.049	0.065			0.088	0.088		0.119	0.119					
3/8	0.675	0.049	0.065			0.091	0.091		0.126	0.126					
1/2	0.840	0.065	0.083			0.109	0.109		0.147	0.147				0.187	0.294
3/4	1.050	0.065	0.083			0.113	0.113		0.154	0.154				0.218	0.308
1	1.315	0.065	0.109			0.133	0.133		0.179	0.179				0.250	0.358
1 1/4	1.660	0.065	0.109			0.140	0.140		0.191	0.191				0.250	0.382
1 1/2	1.900	0.065	0.109			0.145	0.145		0.200	0.200				0.281	0.400
2	2.375	0.065	0.109			0.154	0.154		0.218	0.218				0.343	0.436
2 1/2	2.875	0.083	0.120			0.203	0.203		0.276	0.276				0.375	0.552
3	3.5	0.083	0.120			0.216	0.216		0.300	0.300				0.438	0.600
3 1/2	4.0	0.083	0.120			0.226	0.226		0.318	0.318				-	0.636
4	4.5	0.083	0.120			0.237	0.237	0.281	0.337	0.337		0.438		0.531	0.674
5	5.563	0.109	0.134			0.258	0.258		0.375	0.375		0.500		0.625	0.750
6	6.625	0.109	0.134			0.280	0.280		0.432	0.432		0.562		0.718	0.864
8	8.625	0.109	0.148	0.250	0.277	0.322	0.322	0.406	0.500	0.500	0.593	0.718	0.812	0.906	0.875
10	10.75	0.134	0.165	0.250	0.307	0.365	0.365	0.500	0.500	0.593	0.718	0.843	1.000	1.125	
12	12.75	0.165	0.180	0.250	0.330	0.375	0.406	0.562	0.500	0.687	0.843	1.000	1.125	1.312	
14	14.0		0.250	0.312	0.375	0.375	0.438	0.593	0.500	0.750	0.937	1.093	1.250	1.406	
16	16.0		0.250	0.312	0.375	0.375	0.500	0.656	0.500	0.843	1.031	1.218	1.438	1.593	
18	18.0		0.250	0.312	0.438	0.375	0.562	0.750	0.500	0.937	1.156	1.375	1.562	1.781	
20	20.0		0.250	0.375	0.500	0.375	0.593	0.812	0.500	1.031	1.281	1.500	1.750	1.968	
22	22.0		0.250	0.375	0.500	0.375		0.875	0.500	1.125	1.375	1.625	1.875	2.125	
24	24.0		0.250	0.375	0.562	0.375	0.687	0.968	0.500	1.218	1.531	1.812	2.062	2.343	
26	26.0		0.312	0.500		0.375			0.500						
28	28.0		0.312	0.500	0.625	0.375			0.500						
30	30.0		0.312	0.500	0.625	0.375			0.500						
32	32.0		0.312	0.500	0.625	0.375	0.688		0.500						
34	34.0		0.344	0.500	0.625	0.375	0.688		0.500						
36	36.0		0.312	0.500	0.625	0.375	0.750		0.500						

Birmingham Wire Gage (BWG) and Wall Thickness in mm

TUBE		20	19	18	17	16	15	14	13	12	11	10	9	8	7	6	5
O.D.	I.D.	0.889	1.067	1.245	1.473	1.651	1.829	2.108	2.413	2.769	3.048	3.404	3.759	4.191	4.572	5.156	5.588
1/2	MIN.	10.72	10.36	9.957	9.474	9.068	8.687	8.077	7.391	6.604	5.994						
	NOM.	10.92	10.57	10.21	9.754	9.398	9.042	8.484	7.874	7.163	6.604						
5/8	MIN.	13.89	13.54	13.13	12.65	12.24	11.86	11.25	10.59	9.779	9.169	8.382	7.595	6.655	5.817		
	NOM.	14.10	13.74	13.39	12.93	12.57	12.22	11.66	11.05	10.34	9.779	9.068	8.357	7.493	6.731		
3/4	MIN.	17.07	16.71	16.31	15.82	15.42	15.06	14.43	13.77	12.95	12.34	11.56	10.77	9.83	8.992	7.696	6.756
	NOM.	17.27	16.92	16.56	16.10	15.75	15.39	14.83	14.22	13.51	12.95	12.24	11.53	10.67	9.906	8.738	7.874
7/8	MIN.	20.24	19.89	19.48	18.97	18.59	18.21	17.60	16.92	16.15	15.52	14.73	13.94	13.00	12.17	10.87	9.931
	NOM.	20.45	20.09	19.74	19.28	18.92	18.57	18.01	17.40	16.69	16.13	15.42	14.71	13.84	13.08	11.91	11.05
1	MIN.	23.42	23.06	22.66	22.17	21.77	21.39	20.78	20.09	19.33	18.69	17.93	17.15	16.18	15.34	14.05	13.11
	NOM.	23.62	23.27	22.91	22.45	22.10	21.74	21.18	20.57	19.86	19.30	18.59	17.88	17.02	16.26	15.09	14.22
1-1/8	MIN.	26.59	26.24	25.83	25.32	24.94	24.56	23.95	23.27	22.50	21.87	21.11	20.32	19.35	18.52	17.22	16.28
	NOM.	26.80	26.44	26.09	25.63	25.27	24.92	24.36	23.75	23.04	22.48	21.77	21.06	20.19	19.43	18.26	17.40
1-1/4	MIN.	29.77	29.41	29.01	28.50	28.12	27.74	27.13	26.44	25.68	25.04	24.28	23.50	22.53	21.69	20.40	19.46
	NOM.	29.97	29.62	29.26	28.80	28.45	28.09	27.53	26.92	26.21	26.65	24.94	24.23	23.37	22.61	21.44	20.57
1-3/8	MIN.	32.94	32.59	32.18	31.67	31.29	30.91	30.28	29.62	28.85	28.22	27.46	26.64	25.70	24.87	23.57	22.63
	NOM.	33.15	32.79	32.44	31.98	31.62	31.27	30.71	30.10	29.39	28.83	28.12	27.41	26.54	25.78	24.61	23.75
1-1/2	MIN.	36.12	35.76	35.36	34.85	34.47	34.09	33.48	32.79	32.00	31.39	30.61	29.82	28.88	28.04	26.75	25.81
	NOM.	36.32	36.22	35.61	35.15	34.80	34.44	33.88	33.27	32.56	32.00	61.29	30.58	29.72	28.96	27.79	26.92
1-3/4	MIN.	42.47	42.11	41.71	41.20	40.82	40.44	39.83	39.14	38.35	37.74	36.96	36.17	35.23	34.39	33.10	32.16
	NOM.	118.9	42.32	41.96	41.50	41.15	40.79	40.23	39.62	38.91	38.35	37.64	36.93	36.07	35.31	34.14	33.27
2	MIN.	48.82	48.46	48.06	47.55	47.17	46.79	46.15	45.49	44.70	44.09	43.31	42.52	41.58	40.74	39.45	38.51
	NOM.	49.02	48.67	48.31	47.85	47.50	47.14	46.58	45.97	45.26	44.70	43.99	43.28	42.42	41.66	40.49	39.62
2-1/4	MIN.	55.17	54.81	54.41	53.90	53.52	53.14	52.50	51.84	51.05	50.42	49.66	48.87	47.93	47.09	45.80	44.86
	NOM.	55.37	55.02	54.66	54.20	53.85	53.49	52.93	52.32	51.61	51.05	50.34	49.63	48.77	48.01	46.84	45.97
2-1/2	MIN.	61.52	61.16	60.76	60.25	59.87	59.49	58.85	58.19	57.40	56.79	56.01	55.22	54.28	53.44	52.15	51.21
	NOM.	61.72	61.37	61.01	60.55	60.20	59.84	59.28	58.67	57.96	57.40	56.69	55.98	55.12	54.36	53.19	52.32
2-3/4	MIN.	67.87	67.51	67.11	66.60	66.22	65.84	65.20	64.54	63.75	63.14	62.36	61.57	60.63	59.79	58.50	57.56
	NOM.	68.07	67.72	67.36	66.90	66.55	66.24	65.63	65.02	64.31	63.75	63.04	62.33	61.47	60.71	59.51	58.67
3	MIN.	74.22	73.86	73.46	72.95	72.57	72.19	71.55	70.89	70.10	69.49	68.71	67.92	66.95	66.14	64.85	63.91
	NOM.	74.92	74.07	73.71	73.25	72.90	72.54	71.98	71.37	70.66	70.10	69.39	68.68	67.82	67.06	65.89	65.02
3-1/4	MIN.	80.57	80.21	79.81	79.30	78.92	78.54	78.41	77.24	76.45	75.84	75.06	74.28	73.33	72.49	71.20	70.26
	NOM.	80.77	80.42	80.06	79.60	79.25	78.94	78.33	77.72	77.01	76.45	75.74	75.03	74.17	73.41	72.24	71.37
3-1/2	MIN.	86.92	86.56	86.16	85.65	85.27	84.89	84.25	83.59	82.80	82.19	81.41	80.62	79.68	78.84	77.55	76.61
	NOM.	87.12	86.77	86.41	85.95	85.60	85.24	84.68	84.07	83.36	82.80	82.09	81.38	80.52	79.76	78.59	77.72
3-3/4	MIN.	93.27	92.91	92.51	92.00	91.62	91.24	90.60	89.94	89.15	88.54	87.76	86.97	86.03	85.19	83.90	82.96
	NOM.	93.47	93.12	92.76	92.30	91.95	91.59	91.03	90.42	89.71	89.15	88.44	87.73	86.87	86.11	84.94	84.07
4	MIN.	99.62	99.26	98.86	98.50	97.97	97.59	96.95	96.29	95.50	94.89	94.11	93.32	92.38	91.54	90.25	89.31
	NOM.	99.82	99.47	99.11	98.65	98.30	97.94	97.38	96.77	96.06	96.01	94.79	94.08	93.22	92.46	91.29	90.42
4-1/2	MIN.	112.30	112.00	111.60	111.00	110.70	110.30	109.70	109.00	108.20	107.60	106.80	106.00	105.10	104.20	102.90	102.00
	NOM.	112.50	112.20	111.80	111.40	111.00	110.60	110.10	109.50	108.80	108.20	107.50	106.80	105.90	105.20	104.00	103.10
5	MIN.	125.00	124.70	124.30	123.70	123.40	123.00	122.40	121.70	120.90	120.30	119.50	118.70	117.80	116.90	115.60	114.70
	NOM.	125.20	124.90	124.50	124.10	123.70	123.30	122.80	122.20	121.50	120.90	120.20	119.50	118.60	117.90	116.70	115.80

04 CHAPTER FITTING SERIES

Birmingham Wire Gage (BWG) and Wall Thickness in inches

TUBE		20	19	18	17	16	15	14	13	12	11	10	9	8	7	6	5	
		.035	.042	.049	.058	.065	.072	.083	.095	.109	.120	.134	.148	.165	.180	.203	.220	
O.D.	I.D.																	
1/2	MIN.	.422	.408	.392	.373	.357	.342	.318	.291	.260	.236							
	NOM.	.430	.416	.402	.384	.370	.356	.334	.310	.282	.260							
5/8	MIN.	.547	.533	.517	.498	.482	.467	.443	.417	.385	.361	.330	.299	.262	.229			
	NOM.	.555	.541	.527	.509	.495	.481	.459	.435	.407	.385	.357	.329	.295	.265			
3/4	MIN.	.672	.658	.642	.623	.607	.593	.568	.542	.510	.486	.455	.424	.387	.354	.303	.266	
	NOM.	.680	.666	.652	.634	.620	.606	.584	.560	.532	.510	.482	.454	.420	.390	.344	.310	
7/8	MIN.	.797	.783	.767	.747	.732	.717	.693	.666	.636	.611	.580	.549	.512	.479	.428	.391	
	NOM.	.805	.791	.777	.759	.745	.731	.709	.685	.657	.635	.607	.579	.545	.515	.469	.435	
1	MIN.	.922	.908	.892	.873	.857	.842	.818	.791	.761	.736	.706	.675	.637	.604	.553	.516	
	NOM.	.930	.916	.902	.884	.870	.856	.834	.810	.782	.760	.732	.704	.670	.640	.594	.560	
1-1/8	MIN.	1.047	1.033	1.017	.997	.982	.967	.943	.916	.886	.861	.831	.800	.762	.729	.678	.641	
	NOM.	1.055	1.041	1.027	1.009	.995	.981	.959	.935	.907	.885	.857	.829	.795	.765	.719	.685	
1-1/4	MIN.	1.172	1.158	1.142	1.122	1.107	1.092	1.068	1.041	1.011	.986	.956	.925	.887	.854	.803	.766	
	NOM.	1.180	1.166	1.152	1.134	1.120	1.106	1.084	1.060	1.032	1.010	.982	.954	.920	.890	.844	.810	
1-3/8	MIN.	1.297	1.283	1.267	1.247	1.232	1.217	1.192	1.166	1.136	1.111	1.081	1.049	1.012	.979	.928	.891	
	NOM.	1.305	1.291	1.277	1.259	1.245	1.231	1.209	1.185	1.157	1.135	1.107	1.079	1.045	1.015	.969	.935	
1-1/2	MIN.	1.422	1.408	1.392	1.372	1.357	1.342	1.318	1.291	1.260	1.236	1.205	1.174	1.137	1.104	1.053	1.016	
	NOM.	1.430	1.426	1.402	1.384	1.370	1.356	1.334	1.310	1.282	1.260	1.232	1.204	1.170	1.140	1.094	1.060	
1-3/4	MIN.	1.672	1.658	1.642	1.622	1.607	1.592	1.568	1.541	1.510	1.486	1.455	1.424	1.387	1.354	1.303	1.266	
	NOM.	1.680	1.666	1.652	1.634	1.620	1.606	1.584	1.560	1.532	1.510	1.482	1.454	1.420	1.390	1.344	1.310	
2	MIN.	1.922	1.908	1.892	1.872	1.857	1.842	1.817	1.791	1.760	1.736	1.705	1.674	1.637	1.604	1.553	1.516	
	NOM.	1.930	1.916	1.902	1.884	1.870	1.856	1.834	1.810	1.782	1.760	1.732	1.704	1.670	1.640	1.594	1.560	
2-1/4	MIN.	2.172	2.158	2.142	2.122	2.107	2.092	2.067	2.041	2.010	1.985	1.955	1.924	1.887	1.854	1.803	1.766	
	NOM.	2.180	2.166	2.152	2.134	2.120	2.106	2.084	2.060	2.032	2.010	1.982	1.954	1.920	1.890	1.844	1.810	
2-1/2	MIN.	2.422	2.408	2.392	2.372	2.357	2.342	2.317	2.291	2.260	2.236	2.205	2.174	2.137	2.104	2.053	2.016	
	NOM.	2.430	2.416	2.402	2.384	2.370	2.356	2.334	2.310	2.282	2.260	2.232	2.204	2.170	2.140	2.094	2.060	
2-3/4	MIN.	2.672	2.658	2.642	2.622	2.607	2.592	2.567	2.541	2.510	2.486	2.455	2.424	2.387	2.354	2.303	2.266	
	NOM.	2.680	2.666	2.652	2.634	2.620	2.606	2.584	2.560	2.532	2.510	2.482	2.454	2.420	2.390	2.344	2.310	
3	MIN.	2.922	2.908	2.892	2.872	2.857	2.842	2.817	2.791	2.760	2.736	2.705	2.674	2.637	2.604	2.553	2.516	
	NOM.	2.930	2.916	2.902	2.884	2.870	2.856	2.834	2.810	2.782	2.760	2.732	2.704	2.670	2.640	2.594	2.560	
3-1/4	MIN.	3.172	3.158	3.142	3.122	3.107	3.092	3.067	3.041	3.010	2.985	2.955	2.924	2.887	2.854	2.803	2.766	
	NOM.	3.180	3.166	3.152	3.134	3.120	3.106	3.084	3.060	3.032	3.010	2.982	2.954	2.920	2.890	2.844	2.810	
3-1/2	MIN.	3.422	3.408	3.392	3.372	3.357	3.342	3.317	3.291	3.260	3.236	3.205	3.174	3.137	3.104	3.053	3.016	
	NOM.	3.430	3.416	3.402	3.384	3.370	3.356	3.334	3.310	3.282	3.260	3.232	3.204	3.170	3.140	3.094	3.060	
3-3/4	MIN.	3.672	3.658	3.642	3.622	3.607	3.592	3.567	3.541	3.510	3.486	3.455	3.424	3.387	3.354	3.303	3.266	
	NOM.	3.680	3.666	3.652	3.634	3.620	3.606	3.584	3.560	3.532	3.510	3.482	3.454	3.420	3.390	3.344	3.310	
4	MIN.	3.922	3.908	3.892	3.872	3.857	3.842	3.817	3.791	3.760	3.736	3.705	3.674	3.637	3.604	3.553	3.516	
	NOM.	3.930	3.916	3.902	3.884	3.870	3.856	3.834	3.810	3.782	3.760	3.732	3.704	3.670	3.640	3.594	3.560	
4-1/2	MIN.	4.422	4.408	4.392	4.372	4.357	4.342	4.317	4.291	4.260	4.236	4.205	4.174	4.137	4.104	4.053	4.016	
	NOM.	4.430	4.416	4.402	4.384	4.370	4.356	4.334	4.310	4.282	4.260	4.232	4.204	4.170	4.140	4.094	4.060	
5	MIN.	4.922	4.908	4.892	4.872	4.857	4.842	4.817	4.791	4.760	4.736	4.705	4.674	4.637	4.604	4.553	4.516	
	NOM.	4.930	4.916	4.902	4.884	4.870	4.856	4.834	4.810	4.782	4.760	4.732	4.704	4.670	4.640	4.594	4.560	

ASTM A269 WELDED & BRIGHT ANNEALED STAINLESS STEEL TUBING PRESSURE RATINGS

Nom. Size	Actual O.D.	Nom. Wall	Min. O.D.	Max. O.D.	Max. Ovality	Min. Wall	Weight /Ft	Burst Pressure *** (PSI)	Working Pressure *** (PSI)
1/4									
X .020	0.250	0.020	0.245	0.255	0.005	0.017	0.050	12,000	3,000
X .028	0.250	0.028	0.245	0.255	0.005	0.024	0.066	16,800	4,200
X .035	0.250	0.035	0.245	0.255	0.005	0.030	0.077	21,000	5,250
X .049	0.250	0.049	0.245	0.255	0.005	0.042	0.101	29,400	7,350
5/16									
X .020	0.313	0.020	0.308	0.318	0.005	0.017	0.064	9,585	2,396
X .028	0.313	0.028	0.308	0.318	0.005	0.024	0.085	13,419	3,355
X .035	0.313	0.035	0.308	0.318	0.005	0.030	0.099	16,773	4,193
X .049	0.313	0.049	0.308	0.318	0.005	0.042	0.132	23,482	5,871
3/8									
X .020	0.375	0.020	0.370	0.380	0.005	0.017	0.077	8,000	2,000
X .028	0.375	0.028	0.370	0.380	0.005	0.024	0.103	11,200	2,800
X .035	0.375	0.035	0.370	0.380	0.005	0.030	0.121	14,000	3,500
X .049	0.375	0.049	0.370	0.380	0.005	0.042	0.163	19,600	4,900
X .065	0.375	0.065	0.370	0.380	0.005	0.055	0.213	26,000	6,500
7/16									
X .035	0.437	0.035	0.432	0.442	0.005	0.030	0.150	12,014	3,003
X .065	0.437	0.065	0.432	0.442	0.005	0.055	0.256	22,311	5,578
1/2									
X .020	0.500	0.020	0.495	0.505	0.005	0.018	0.104	6,000	1,500
X .028	0.500	0.028	0.495	0.505	0.005	0.025	0.141	8,400	2,100
X .035	0.500	0.035	0.495	0.505	0.005	0.032	0.173	10,500	2,625
X .049	0.500	0.049	0.495	0.505	0.005	0.044	0.235	14,700	3,675
X .065	0.500	0.065	0.495	0.505	0.005	0.059	0.299	19,500	4,875
X .083	0.500	0.083	0.495	0.505	0.005	0.075	0.362	24,900	6,225
X .095	0.500	0.095	0.495	0.505	0.005	0.086	0.402	28,500	7,125
X .109	0.500	0.109	0.495	0.505	0.005	0.098	0.447	32,700	8,175
5/8									
X .020	0.625	0.020	0.620	0.630	0.008	0.018	0.132	4,800	1,200
X .028	0.625	0.028	0.620	0.630	0.008	0.025	0.178	6,720	1,680
X .035	0.625	0.035	0.620	0.630	0.008	0.032	0.220	8,400	2,100
X .042	0.625	0.042	0.623	0.628	0.003	0.040	0.268	10,080	2,520
X .049	0.625	0.049	0.620	0.630	0.008	0.044	0.300	11,760	2,940
X .065	0.625	0.065	0.620	0.630	0.005	0.059	0.384	15,600	3,900
X .083	0.625	0.083	0.620	0.630	0.005	0.075	0.470	19,920	4,980
X .095	0.625	0.095	0.620	0.630	0.005	0.086	0.524	22,800	5,700
X .109	0.625	0.109	0.620	0.630	0.005	0.098	0.588	26,160	6,540

04 CHAPTER FITTING SERIES

ASTM A269 WELDED & BRIGHT ANNEALED STAINLESS STEEL TUBING PRESSURE RATINGS

Nom. Size	Actual O.D.	Nom. Wall	Min. O.D.	Max. O.D.	Max. Ovality	Min. Wall	Weight /Ft	Burst Pressure *** (PSI)	Working Pressure *** (PSI)
3/4									
X .020	0.750	0.020	0.745	0.755	0.008	0.018	0.159	4,000	1,000
X .025	0.750	0.025	0.745	0.755	0.008	0.023	0.207	5,000	1,250
X .028	0.750	0.028	0.745	0.755	0.008	0.025	0.215	5,600	1,400
X .035	0.750	0.035	0.745	0.755	0.008	0.032	0.266	7,000	1,750
X .049	0.750	0.049	0.745	0.755	0.008	0.044	0.365	9,800	2,450
X .065	0.750	0.065	0.745	0.755	0.005	0.059	0.47	13,000	3,250
X .083	0.750	0.083	0.745	0.755	0.005	0.075	0.577	16,600	4,150
X .095	0.750	0.095	0.745	0.755	0.005	0.086	0.646	19,000	4,750
X .109	0.750	0.109	0.745	0.755	0.005	0.098	0.729	21,800	5,450
7/8									
X .020	0.875	0.020	0.870	0.880	0.008	0.018	0.186	3,429	857
X .025	0.875	0.025	0.870	0.880	0.008	0.023	0.242	4,286	1,071
X .028	0.875	0.028	0.870	0.880	0.008	0.025	0.252	4,800	1,200
X .035	0.875	0.035	0.870	0.880	0.008	0.032	0.313	6,000	1,500
X .049	0.875	0.049	0.870	0.880	0.008	0.044	0.430	8,400	2,100
X .065	0.875	0.065	0.870	0.880	0.005	0.059	0.555	11,143	2,786
X .083	0.875	0.083	0.870	0.880	0.005	0.075	0.685	14,229	3,557
X .095	0.875	0.095	0.870	0.880	0.005	0.086	0.768	16,286	4,071
X .109	0.875	0.109	0.870	0.880	0.005	0.098	0.870	18,686	4,671
1									
X .020	1.000	0.020	0.995	1.005	0.008	0.018	0.213	3,000	750
X .028	1.000	0.028	0.995	1.005	0.008	0.025	0.289	4,200	1,050
X .035	1.000	0.035	0.995	1.005	0.008	0.032	0.359	5,250	1,313
X .049	1.000	0.049	0.995	1.005	0.008	0.044	0.496	7,350	1,838
X .065	1.000	0.065	0.995	1.005	0.005	0.059	0.640	9,750	2,438
X .083	1.000	0.083	0.995	1.005	0.005	0.075	0.792	12,450	3,113
X .095	1.000	0.095	0.995	1.005	0.005	0.086	0.891	14,250	3,563
X .109	1.000	0.109	0.995	1.005	0.005	0.098	1.011	16,350	4,088
6mm									
X 1mm	0.236	0.039	0.231	0.241	0.005	0.033	0.084	25,023	6,256
8mm X									
1mm	0.315	0.039	0.310	0.320	0.005	0.033	0.118	18,574	4,643
10mm X									
1mm	0.394	0.039	0.389	0.399	0.005	0.033	0.151	14,859	3,715
12mm X									
1mm	0.472	0.039	0.467	0.477	0.005	0.033	0.185	12,383	3,096
20mm X									
1mm	0.787	0.039	0.782	0.792	0.005	0.035	0.319	7,433	1,858

PressureFormula

$$\text{Internal Burst} = 2 St/D$$

- Where P = Internal pressure psi
- S = Tensile stress psi
- t = Minimum wall thickness in inches
- D = Nominal outside diameter in inches
- Working pressure = 1/4 internal burst pressure

TensileRequirements (304, 304L, 316, 316L)

- A minimum of (2) tests per work order / heat number
- Minimum yield strength = 30,000 psi
- Minimum ultimate strength = 75,000 psi
- Minimum elongation = 35%

HardnessRequirements (304, 304L, 316, 316L)

- A minimum of (2) tests per work order / heat number
- Maximum hardness* = 74 30T or 90 RB

Not applicable to sizes < 0.250 I.D. unless specified

B.W.G. To Decimal Conversion Chart

B.W. GA.	DECIMAL EQUIV.	B.W. GA.	DECIMAL EQUIV.	B.W. GA.	DECIMAL EQUIV.	B.W. GA.	DECIMAL EQUIV.
1	0.300	10	0.134	19	0.042	28	0.014
2	0.284	11	0.120	20	0.035	29	0.013
3	0.259	12	0.109	21	0.032	30	0.012
4	0.238	13	0.095	22	0.028	31	0.010
5	0.220	14	0.083	23	0.025	32	0.009
6	0.203	15	0.072	24	0.022	33	0.008
7	0.180	16	0.065	25	0.020	34	0.007
8	0.165	17	0.058	26	0.018	35	0.005
9	0.148	18	0.049	27	0.016	36	0.004

04 CHAPTER FITTING SERIES

ASTM A312 / ASME SA312 WELDED STAINLESS STEEL PIPE PRESSURE RATINGS

Nom. Size	Actual O.D.	Nom. Wall	Min. O.D.	Max. O.D.	Max. Ovality	Min. Wall	Weight /Ft	Burst Pressure *** (PSI)	Working Pressure *** (PSI)
1/8"									
Sch 5	0.405	0.035	0.395	0.413	0.006	0.031	0.136	12963	3241
Sch 10	0.405	0.049	0.395	0.413	0.006	0.043	0.184	18148	4537
Sch 40	0.405	0.068	0.395	0.413	0.006	0.060	0.239	25185	6296
1/4"									
Sch 5	0.540	0.049	0.530	0.548	0.006	0.043	0.253	13611	3403
Sch 10	0.540	0.065	0.530	0.548	0.006	0.057	0.333	18056	4514
Sch 40	0.540	0.088	0.530	0.548	0.006	0.077	0.408	24444	6111
3/8"									
Sch 10	0.675	0.065	0.665	0.683	0.006	0.057	0.427	14444	3611
Sch 40	0.675	0.091	0.665	0.683	0.006	0.080	0.543	20222	5056
1/2"									
Sch 5	0.840	0.065	0.830	0.848	0.010	0.057	0.543	11607	2902
Sch 10	0.840	0.083	0.830	0.848	0.010	0.073	0.643	14821	3705
Sch 40	0.840	0.109	0.830	0.848	0.010	0.095	0.808	19464	4866
Sch 80	0.840	0.147	0.830	0.848	0.010	0.129	1.059	26250	6563
3/4"									
Sch 5	1.050	0.065	1.040	1.058	0.010	0.057	0.690	9286	2321
Sch 10	1.050	0.083	1.040	1.058	0.010	0.073	0.820	11857	2964
Sch 40	1.050	0.113	1.040	1.058	0.010	0.099	1.079	16143	4036
Sch 80	1.050	0.154	1.040	1.058	0.010	0.135	1.426	22000	5500
1"									
Sch 5	1.315	0.065	1.305	1.323	0.010	0.057	0.875	7414	1854
Sch 10	1.315	0.109	1.305	1.323	0.010	0.095	1.327	12433	3108
Sch 40	1.315	0.133	1.305	1.323	0.010	0.116	1.590	15171	3793
Sch 80	1.315	0.179	1.305	1.323	0.010	0.157	2.085	20418	5105

Theoretical burst and working pressure in psi to 100 degrees F

PressureFormula

$$\text{Internal Burst} = 2 St/D$$

- Where P = Internal pressure psi
- S = Tensile stress psi
- t = Minimum wall thickness in inches
- D = Nominal outside diameter in inches
- Working pressure = 1/4 internal burst pressure

TensileRequirements (304, 304L, 316, 316L)

- A minimum of (2) tests per work order / heat number
- Minimum yield strength = 30,000 psi
- Minimum ultimate strength = 75,000 psi
- Minimum elongation = 35%

HardnessRequirements (304, 304L, 316, 316L)

- A minimum of (2) tests per work order / heat number
- Maximum hardness* = 74 30T or 90 RB

Not applicable to sizes < 0.250 I.D. unless specified

Corrosion Resistance Guide

Media Conveyed or Atmosphere	Temperature	AISI type 304	AISI type 316	Media Conveyed or Atmosphere	Temperature	AISI type 304	AISI type 316
Acetone		◎	◎	Carbonated Water		◎	◎
Acetylene		◎	◎	Sodium Carbonate		◎	◎
Sulfur.Dioxide (Moist)		△	○	Nitrogen		◎	◎
Sulfur.Dioxide (Dry)		◎	◎	Trichlor Ethylene (Dry)		◎	◎
Ethyl Alcohol		◎	◎	Trichlor Ethylene (Moist)		△	△
Methyl Alcohol		◎	◎	Naphtha		◎	◎
Ammonia	R.T.	◎	◎	Benzene		◎	◎
Ammonia	Hot	△	△	Hydrogen Sulfide (Dry)	H65°C	◎	◎
Sulfar (Dry)		◎	◎	Hydrogen Sulfide (Moise)		○	○
Sulfar (Wet)	R.T.	*○	*◎	Ammonium Sulfate (1%)	R.T	◎	◎
Sulfar (Molten)		△	△	Ammonium Sulfate (5% Aeration)	R.T	◎	◎
Sulfar (Moist)	R.T.	△	△	Ammonium Sulfate (10%)	Boil	*○	*◎
Ethylene Glvcol		◎	◎	Calcium Sulfate	R.T	◎	◎
Ethers		◎	◎	Copper Sulfate Solution		◎	◎
Aluminum Chloride		△	△	Sodium Sulfate (5%)	R.T	○	◎
Iron Chloride		△	△	Sodium Sulfate (Conc)	R.T	◎	◎
Magnesium Chloride		△	△	Barium Sulfate	R.T	◎	◎
Chlorine (Dry)		△	○	Phospholic Acid (≤5%)	R.T	◎	◎
Chlorine (Moist)		△	△	Phospholic Acid (5 ~ 25%)		△	○
Hydrogen Peroxide	R.T.	*◎	◎	Phospholic Acid (25~ 50%)		△	△
Hydrogen Peroxide	Boil	*○	◎	Chloric Acid (< 5%)		△	○
Sea Water		△	△	Chloric Acid (≥ 5%)		△	△
Gasoline		◎	◎	Nitric Acid (< 50%)		◎	◎
Glycerin		◎	◎	Nitric Acid (65%)	R.T	◎	◎
Crude Oil		◎	◎	Nitric Acid (≥50%)	Boil	○	○
Ethyl Acetate		◎	◎	Nitric Acid (Conc)	R.T	○	○
Oxygen		◎	◎	Nitric Acid (Conc)	Boil	△	△
Carbon Tetrachloride (Dry)		◎	◎	Sulfuric Acid (95 ~ 100%)		◎	◎
Carbon Tetrachloride with water		△	△	Sulfuric Acid (75 ~ 95%)		○	○
Steam		◎	◎	Sulfuric Acid (< 75%)		△	△
Oxalic Acid (< 10%)	R.T.	◎	◎	Sulfuric Acid (anhydrous)	R.T.	◎	◎
Oxalic Acid (10%)	Boil	△	△	Sulfuric Acid (anhydrous)	Boil	△	△
Oxalic Acid (> 10%)		△	△	Fluoric Acid		△	△
Mercury		◎	◎	Acetic Acid	R.T.	◎	◎
Potassium Hydroxide (< 10%)		◎	◎	Acetic Acid	Boil	△	△
Potassium Hydroxide (10%~ 70%)	R.T.	◎	◎	Sodium Hydroxide (< 10%)		◎	◎
Potassium Hydroxide (50%)	Boil	○	○	Sodium Hydroxide (10 ~ 50%)	< 100°C	◎	◎
Barium Hydroxide (≤ 10%)		◎	◎	Sodium Hydroxide (10 ~ 50%)	Boil	○	○
Barium Hydroxide (100% ~ 70%)	R.T.	◎	◎	Sodium Hydroxide (50 ~ 70%)	< 100°C	◎	◎
Bromium		△	△	Sodium Hydroxide (50 ~ 70%)	100°C~150°C	○	○
Tar		◎	◎	Sodium Hydroxide (70 ~ anhydrous)	< 260°C	○	○
Carbon Dioxide		◎	◎	Sodium Hydroxide (Molten)	< 480°C	△	△

◎ : Suitable (normal conditions) ○ : Limited Service △ : Unsuitable
 * : Susceptible to pitting corrosion where contacting with air.
 Note : R.T. : Room Temperature

Conical Reducers

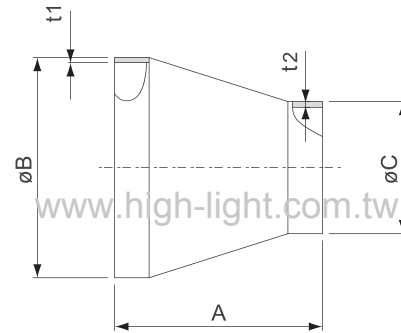

Model No.	Material	A	B	C	t1	t2	Parts No.
25-16CR	304 S.S.	35	25.4	19.05	1.65	1.65	16230030024
40-16CR	304 S.S.	60.3	38.1	19.05	1.65	1.65	16230050024
40-25CR	304 S.S.	60.3	38.1	25.4	1.65	1.65	16230050034
50-25CR	304 S.S.	60.3	50.8	25.4	1.65	1.65	16230060034
50-40CR	304 S.S.	60.3	50.8	38.1	1.65	1.65	16230060054
63-40CR	304 S.S.	60.3	63.5	38.1	1.65	1.65	16230070054
63-50CR	304 S.S.	60.3	63.5	50.8	1.65	1.65	16230070064
80-50CR	304 S.S.	92	76.2	50.8	1.65	1.65	16230080064
80-63CR	304 S.S.	92	76.2	63.5	1.65	1.65	16230080074
100-50CR	304 S.S.	92	101.6	50.8	2.1	1.65	16230090064
100-63CR	304 S.S.	92	101.6	63.5	2.1	1.65	16230090074
100-80CR	304 S.S.	92	101.6	76.2	2.1	1.65	16230090084
150-80CR	304 S.S.	152.4	152.4	76.2	2.77	1.65	16230110084
150-100CR	304 S.S.	152.4	152.4	101.6	2.77	2.1	16230110094

90° Elbows

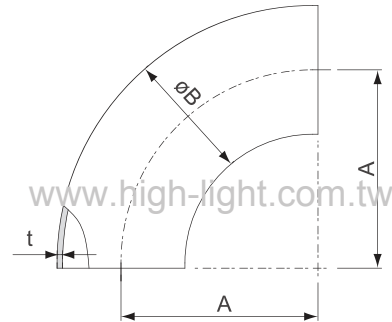

Model No.	Material	A	B	t	Parts No.
16EL90A	304 S.S.	28.6	19.05	1.65	16030020024
25EL90A	304 S.S.	38.1	25.4	1.65	16030030034
40EL90A	304 S.S.	57.2	38.1	1.65	16030050054
50EL90A	304 S.S.	76.2	50.8	1.65	16030060064
63EL90A	304 S.S.	95.2	63.5	1.65	16030070074
80EL90A	304 S.S.	114.3	76.2	1.65	16030080084
100EL90A	304 S.S.	152.4	101.6	2	16030090094
150EL90A	304 S.S.	228.6	152.4	2.7	16030110114

90° Elbows with Tangents

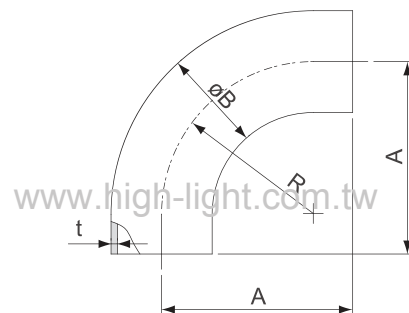

Model No.	Material	A	B	R	t	Parts No.
16ELT90A	304 S.S.	34.5	19.05	28.6	1.65	16240020024
25ELT90A	304 S.S.	52.4	25.4	38.1	1.65	16240030034
40ELT90A	304 S.S.	74.6	38.1	57.2	1.65	16240050054
50ELT90A	304 S.S.	103.2	50.8	76.2	1.65	16240060064
63ELT90A	304 S.S.	131.8	63.5	95.3	1.65	16240070074
80ELT90A	304 S.S.	160.3	76.2	114.3	1.65	16240080084
100ELT90A	304 S.S.	211.1	101.6	152.4	2	16240090094

45° Elbows

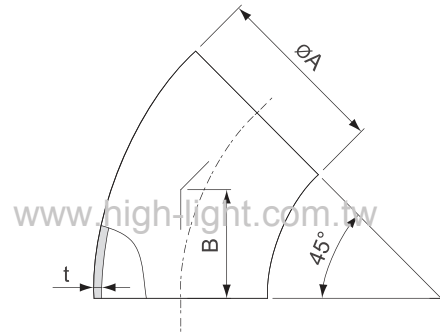

Model No.	Material	A	B	t	Parts No.
16EL45A	304 S.S.	19.05	11.8	1.65	16070020024
25EL45A	304 S.S.	25.4	15.9	1.65	16070030034
40EL45A	304 S.S.	38.1	23.8	1.65	16070050054
50EL45A	304 S.S.	50.8	31.8	1.65	16070060064
63EL45A	304 S.S.	63.5	39.7	1.65	16070070074
80EL45A	304 S.S.	76.2	47.6	1.65	16070080084
100EL45A	304 S.S.	101.6	63.5	2	16070090094

45° Elbows with Tangents

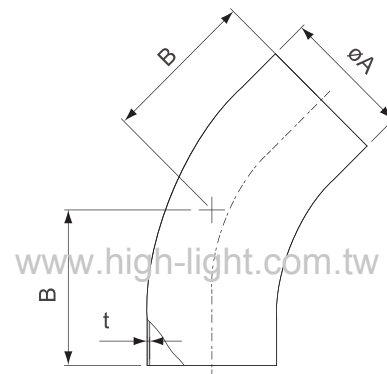

Model No.	Material	A	B	t	Parts No.
16ELT45A	304 S.S.	19.05	19.3	1.65	16250020024
25ELT45A	304 S.S.	25.4	30.2	1.65	16250030034
40ELT45A	304 S.S.	38.1	41.3	1.65	16250050054
50ELT45A	304 S.S.	50.8	58.7	1.65	16250060064
63ELT45A	304 S.S.	63.5	76.2	1.65	16250070074
80ELT45A	304 S.S.	76.2	93.7	1.65	16250080084
100ELT45A	304 S.S.	101.6	122.2	2	16250090094

04 CHAPTER FITTING SERIES

Tees

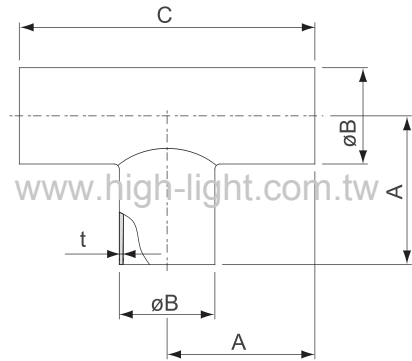

Model No.	Material	A	B	C	t	Parts No.
16TA	304 S.S.	34.5	19.05	69	1.65	16150020024
25TA	304 S.S.	47.6	25.4	95.2	1.65	16150030034
40TA	304 S.S.	57.2	38.1	114.3	1.65	16150050054
50TA	304 S.S.	76.2	50.8	152.4	1.65	16150060064
63TA	304 S.S.	76.2	63.5	152.4	1.65	16150070074
80TA	304 S.S.	82.5	76.2	165.1	1.65	16150080084
100TA	304 S.S.	98.4	101.6	196.8	2	16150090094
150TA	304 S.S.	127	152.4	254	2.7	16150110114

4-Way Crosses

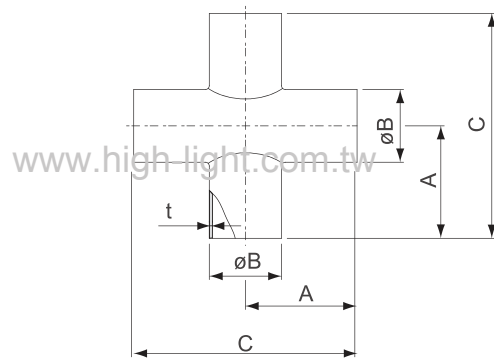

Model No.	Material	A	B	C	t	Parts No.
16XA	304 S.S.	34.5	19.05	69	1.65	16190020024
25XA	304 S.S.	47.6	25.4	95.2	1.65	16190030034
40XA	304 S.S.	57.2	38.1	114.3	1.65	16190050054
50XA	304 S.S.	76.2	50.8	152.4	1.65	16190060064
63XA	304 S.S.	76.2	63.5	152.4	1.65	16190070074
80XA	304 S.S.	82.5	76.2	165.1	1.65	16190080084
100XA	304 S.S.	98.4	101.6	196.8	2	16190090094
150XA	304 S.S.	127	152.4	254	2.7	16190110114

Unequal Tees

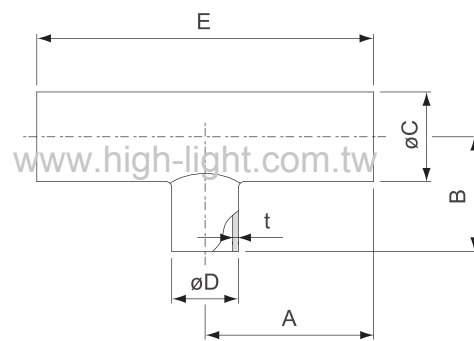

Model No.	Material	A	B	C	D	E	t	Parts No.
25UT16A	304 S.S.	48.2	33.7	25.4	19.05	96.4	1.65	16170030024
40UT16A	304 S.S.	57.2	48.2	38.1	19.05	114.3	1.65	16170050024
40UT25A	304 S.S.	57.2	54	38.1	25.4	114.3	1.65	16170050034
50UT16A	304 S.S.	76.2	54.4	50.8	19.05	152.4	1.65	16170060024
50UT25A	304 S.S.	76.2	60.3	50.8	25.4	152.4	1.65	16170060034
50UT40A	304 S.S.	76.2	63.5	50.8	38.1	152.4	1.65	16170060054
80UT63A	304 S.S.	82.5	82.5	76.2	63.5	165	1.65	16170080074
100UT50A	304 S.S.	98.4	101.6	101.6	50.8	196.8	2	16170090064
100UT63A	304 S.S.	98.4	95.3	101.6	63.5	196.8	2	16170090074
100UT80A	304 S.S.	98.4	95.3	101.6	76.2	196.8	2	16170090084
150UT80A	304 S.S.	127	120.7	152.4	76.2	254	2.77	16170110084
150UT100A	304 S.S.	127	123.8	152.4	101.6	254	2.77	16170110094

Unequal 4-Ways Crosses

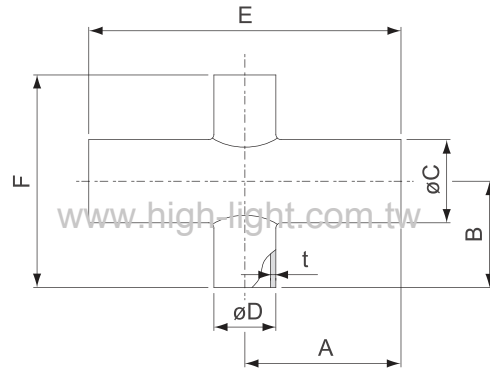
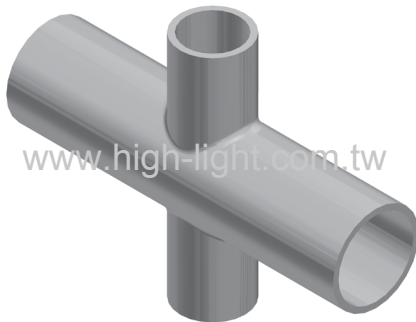

Model No.	Material	A	B	C	D	E	F	t	Parts No.
25UX16A	304 S.S.	48.2	33.7	25.4	19.05	96.4	67.4	1.65	16210030024
40UX16A	304 S.S.	57.2	48.2	38.1	19.05	114.3	96.4	1.65	16210050024
40UX25A	304 S.S.	57.2	54	38.1	25.4	114.3	108	1.65	16210050034
50UX16A	304 S.S.	76.2	54.4	50.8	19.05	152.4	108.8	1.65	16210060024
50UX25A	304 S.S.	76.2	60.3	50.8	25.4	152.4	120.6	1.65	16210060034
50UX40A	304 S.S.	76.2	63.5	50.8	38.1	152.4	127	1.65	16210060054
80UX63A	304 S.S.	82.5	82.5	76.2	63.5	165	165	1.65	16210080074
100UX50A	304 S.S.	98.4	101.6	101.6	50.8	196.8	203.2	2	16210090064
100UX63A	304 S.S.	98.4	95.3	101.6	63.5	196.8	190.6	2	16210090074
100UX80A	304 S.S.	98.4	95.3	101.6	76.2	196.8	190.6	2	16210090084
150UX80A	304 S.S.	127	120.7	152.4	76.2	254	241.4	2.77	16210110084
150UX100A	304 S.S.	127	123.8	152.4	101.6	254	247.6	2.77	16210110094

Five-Way Crosses

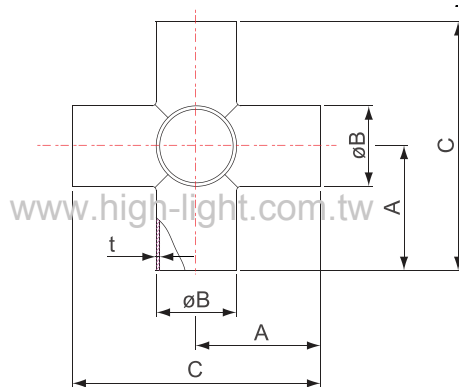

Model No.	Material	A	B	C	t	Parts No.
16FXA	304 S.S.	34.5	19.05	69	1.65	16260020024
25FXA	304 S.S.	47.6	25.4	95.2	1.65	16260030034
40FXA	304 S.S.	57.2	38.1	114.3	1.65	16260050054
50FXA	304 S.S.	76.2	50.8	152.4	1.65	16260060064
63FXA	304 S.S.	76.2	63.5	152.4	1.65	16260070074
80FXA	304 S.S.	82.5	76.2	165.1	1.65	16260080084
100FXA	304 S.S.	98.4	101.6	196.8	2	16260090094
150FXA	304 S.S.	127	152.4	254	2.7	16260110114

Six-Way Crosses

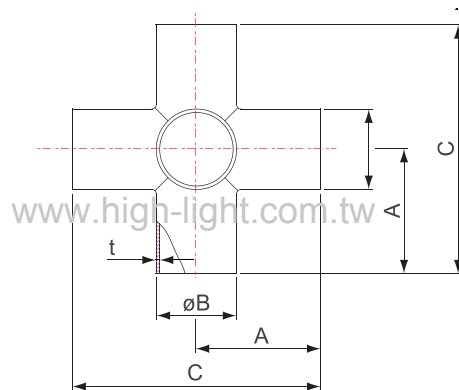

Model No.	Material	A	B	C	t	Parts No.
16FXA	304 S.S.	34.5	19.05	69	1.65	16280020024
25FXA	304 S.S.	47.6	25.4	95.2	1.65	16280030034
40FXA	304 S.S.	57.2	38.1	114.3	1.65	16280050054
50FXA	304 S.S.	76.2	50.8	152.4	1.65	16280060064
63FXA	304 S.S.	76.2	63.5	152.4	1.65	16280070074
80FXA	304 S.S.	82.5	76.2	165.1	1.65	16280080084
100FXA	304 S.S.	98.4	101.6	196.8	2	16280090094
150FXA	304 S.S.	127	152.4	254	2.7	16280110114



Htc 日揚科技

www.high-light.com.tw

總公司 Headquarters

709 台南市安南區工明南二路106號

No. 106, Gung-Min South Road II, An-Nan Area, Tainan City 709, Taiwan (R.O.C.)

TEL +886-6-2460296 FAX +886-6-2478022

<http://www.high-light.com.tw> Mail: ec@high-light.com.tw

台南二廠 Tainan Factory II

709 台南市安南區工明南一路101號

No. 101 Gung-Min South Road 1, An-Nan Area, Tainan City 709, Taiwan (R.O.C.)

TEL +886-6-5116111 FAX +886-6-2564001 +886-6-5105168

日揚電子科技（上海）有限公司 Shanghai. Highlight Tech Co., Ltd.

200444 上海市寶山城市工業園區域銀路51號

No. 51, Cheng Yin Rd, Baoshan City Industrial Zone, Shanghai 200444, China

TEL +86-21-36162036 FAX +86-21-36162037

<http://www.high-light.com.cn> Mail: ec@high-light.com.tw

新竹技術服務中心 HSIN-CHU Technology Service Center

303 新竹縣湖口鄉鳳山村中華路13號

No. 13, Zhonghua Road, Fengshan Village, Hukou Township, Hsinchu County, 303, Taiwan (R.O.C.)

TEL: +886-3-5973325 FAX: +886-3-5973083