

BEHRINGER®

*The Best
Solution For
Process
Piping
Installations*

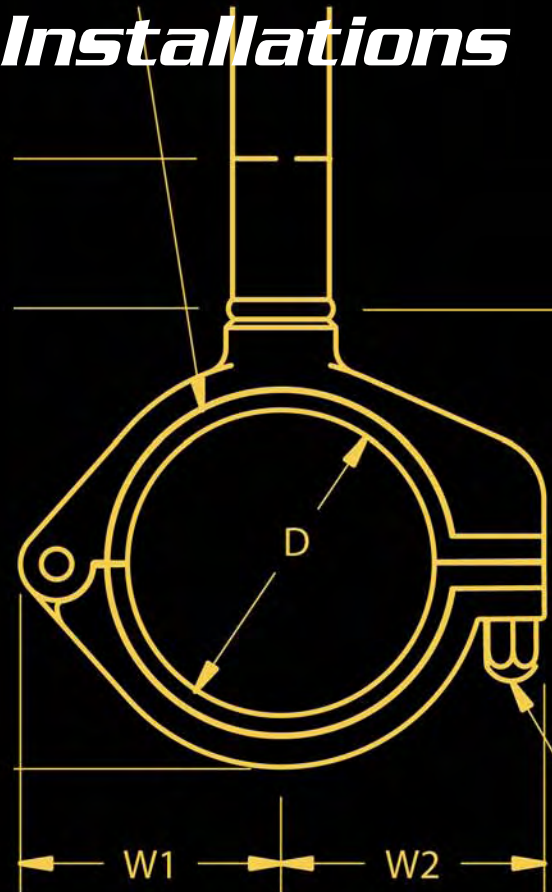
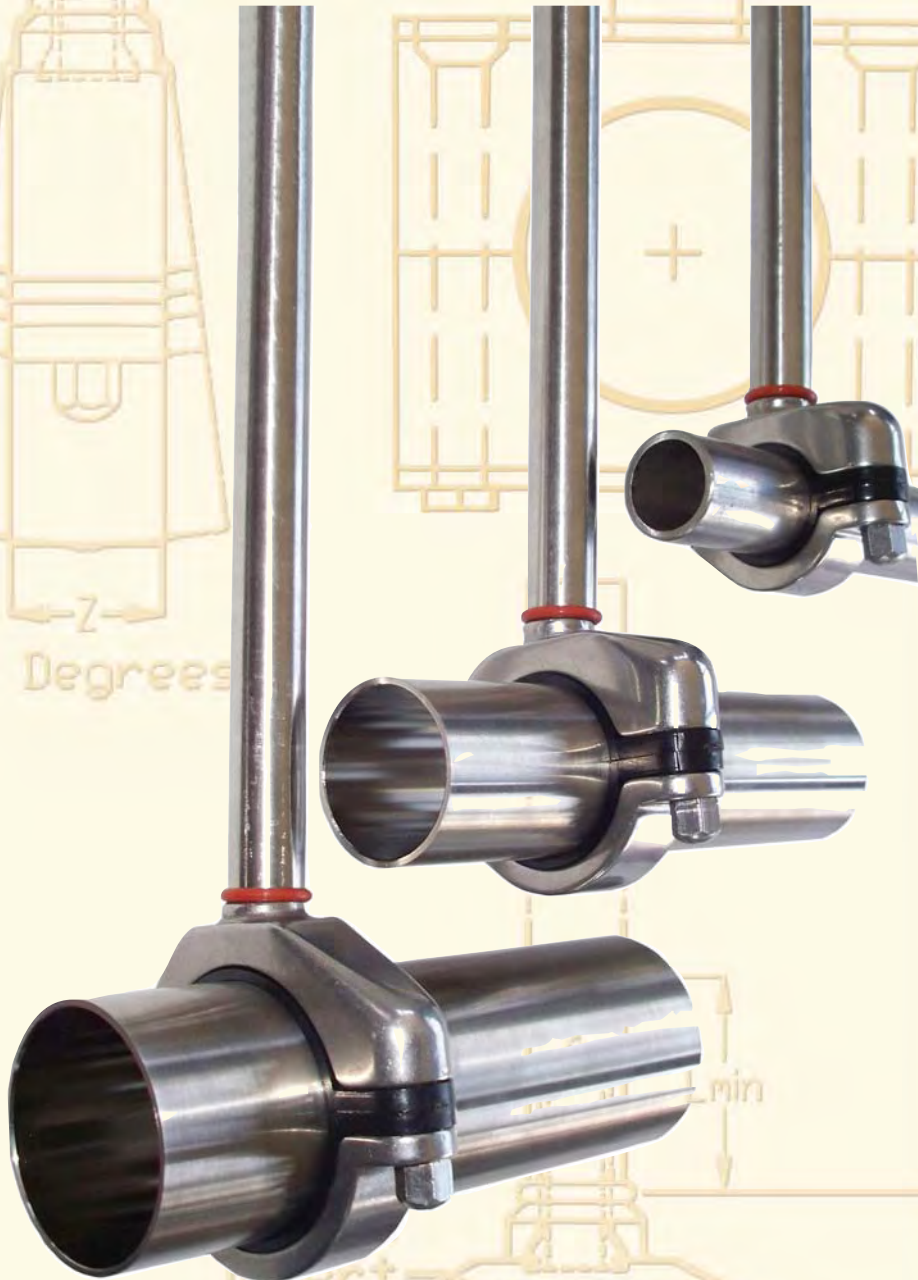

**17 Ridge Road
Branchville, NJ 07826**

Phone: 973-948-0226

Fax: 973-948-2562

www.behringersystems.com

cserv@behringersystems.com

Introduction

Thank you for choosing Behringer, the world's leading manufacturer of Pipe and Tube supports. Behringer has been manufacturing pipe clamps and support systems for over 30 years, and has developed a reputation in the industrial and sanitary markets that is second to none. We have made developments and product improvements over the years both strengthening and broadening our product offering. This is evident in the breadth of our line and ability to accommodate new applications and designs. You can count on Behringer for all your clamping and support requirements.

Product

Behringer Hygienic Tube Supports are designed to meet the high demands of process piping in hygienic service applications. The automatic slope adjustment feature of the CH Series Dynamic hanger will promote drainability of the piping without imparting unnecessary stress into the piping. Drainability is a critical design feature in hygienic process piping. Behringer Sanitary Pipe and Tube Supports are available in a wide range of sizes and configurations and are offered with both an anchor or guide insert to meet the needs of any application.

Behringer offers many different series and within each series there are many different configurations available. We offer options for mounting such as welding, bolting, rail and strut mounting, double, and group mounting, etc. Behringer always welcomes a challenge, and would be happy to work with you to design a product that is custom-tailored to your application. This is where many of our developments are first generated, and helps to further progress the complexity of our product. Challenge us with your requirements.

Guarantee

Behringer Corporation, hereinafter called the "MANUFACTURER", guarantees that this product shall be free from defects in workmanship and materials. THIS GUARANTEE IS IN LIEU OF ALL OTHER GUARANTEES EITHER EXPRESSED OR IMPLIED, INCLUDING GUARANTEES FOR FITNESS FOR PURPOSE INTENDED. The MANUFACTURER'S liability is limited to the replacement of any materials which, after inspection by the MANUFACTURER at its sole option, are found to be defective. The MANUFACTURER will honor only those claims that are presented to it within one hundred eighty (180) days of the delivery of the materials to the purchaser. The MANUFACTURER SPECIFICALLY DISCLAIMS ANY AND ALL LIABILITY FOR CONSEQUENTIAL DAMAGES. The MANUFACTURER shall not be liable for any damages which arise out of the misuse or abuse of the products.

Applications

Behringer clamps are used in many different types of applications ranging from low pressure lubrication and water systems to high pressure hydraulic and process systems. Anywhere that there are pipes, tubes, or hoses is a viable application for Behringer clamps. Behringer clamps are used in the following markets and applications most frequently:

Mobile Equipment
Mining Equipment
Offshore and Marine Applications
Shipbuilding
Instrumentation
Nuclear
General Construction
Electrical / Mechanical Contracting
Process Piping
Pharmaceutical / Biotechnology
Food and Dairy
Beverage

Power Generation
Pulp and Paper
Industrial Hydraulics
Power Units
Agricultural Equipment
OEM Machinery

Assistance

Behringer Corporation has a competent and highly skilled staff of inside sales and customer service personnel available to assist you with any of your needs. Behringer can be reached in the following ways:

Post Mail: Behringer Corporation
17 Ridge Road
Branchville, NJ 07826
Telephone: +1 (973) 948-0226
Fax: +1 (973) 948-2562
Email: cserv@behringersystems.com

Our regular business hours are Monday through Friday, 8AM - 5 PM Eastern Time. For after-hours service, please contact your regional sales manager.

Please Read

The information contained in this document is provided as an aid in properly selecting products and/or options. It is intended to be used by technically experienced users for general reference only. The supplier assumes no responsibility or liability for the accuracy or completeness of this document, as well as results obtained by the use of this information. Due to the variety of possible operating conditions, it is highly recommended that the user make their own tests to determine the safety and suitability of all products and combinations thereof. The user is solely responsible for final determination of such conditions.

CH SERIES HAS ALL YOUR ANGLES COVERED...

Compact Hygienic CH Series Hangers

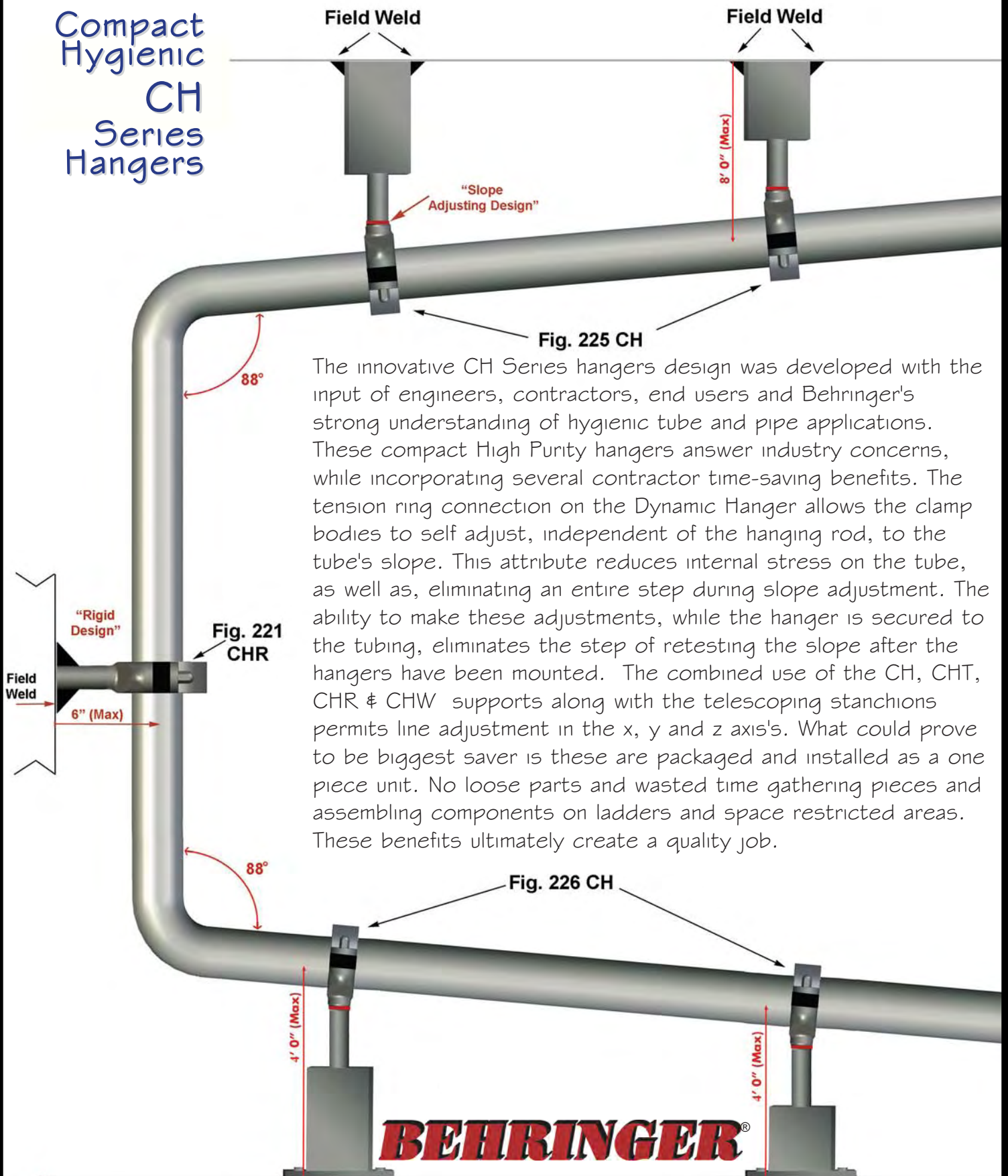

Fig. 225 CH

The innovative CH Series hangers design was developed with the input of engineers, contractors, end users and Behringer's strong understanding of hygienic tube and pipe applications. These compact High Purity hangers answer industry concerns, while incorporating several contractor time-saving benefits. The tension ring connection on the Dynamic Hanger allows the clamp bodies to self adjust, independent of the hanging rod, to the tube's slope. This attribute reduces internal stress on the tube, as well as, eliminating an entire step during slope adjustment. The ability to make these adjustments, while the hanger is secured to the tubing, eliminates the step of retesting the slope after the hangers have been mounted. The combined use of the CH, CHT, CHR & CHW supports along with the telescoping stanchions permits line adjustment in the x, y and z axis's. What could prove to be biggest saver is these are packaged and installed as a one piece unit. No loose parts and wasted time gathering pieces and assembling components on ladders and space restricted areas. These benefits ultimately create a quality job.

BEHRINGER®

New Items & Accessories

Height Adjustment Coupling



Polysulfone Inserts for Smooth Bore Series



Ball Swivel Joint - SWVJ



Fig. 207 Thermal Expansion Guide (TEG) for Plastic Inserts

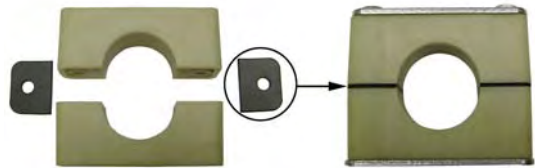

Wing Bolt - CWBT



Fig. 65 Ceiling Mounting Plate



5/16" x 3/8" Adapter

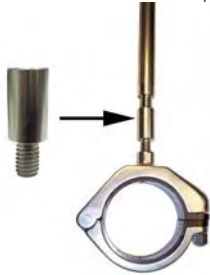
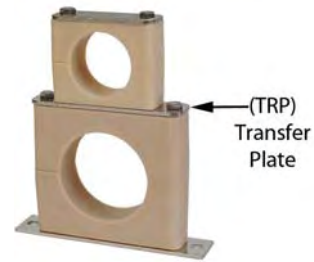

Fig. 205 Transfer Plate Assembly



Convenient T-Handle Nut Driver



Slope Line Lock for Fig. 203 (RAL-1)



BEHRINGER®

Table of Contents



CH Series

Fig. 221

CH - Dynamic Mount Hanger

CHR - Rigid Mount Hanger

CHW - Weld Plate Mount Support

CHT - Threaded Mount Hanger

Fig. 245 - Threaded Support Rod

Pages 4 - 5

Pages 6 - 7

Pages 8 - 9

Pages 10 - 11

Page 12

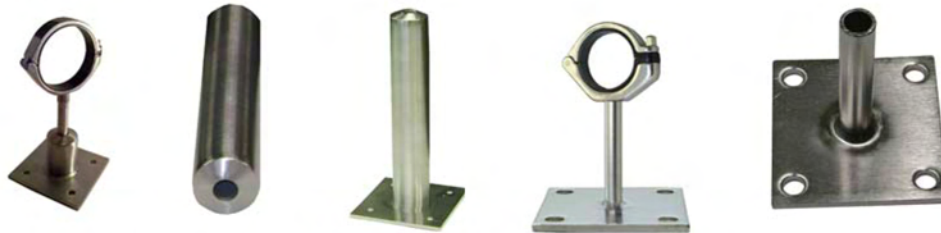

Stanchions

Fig. 223 - Telescopic Adjusting Round Floor Mount Stand

Fig. 224 - CH Series Rod Stand Plate

Fig. 225 - Telescopic Adjusting Stanchion - Hang Mount

Fig. 226 - Telescopic Adjusting Stanchion - Floor Mount

Page 13

Page 14

Page 15

Page 16

Smooth Bore Series

Fig. 200 - Smooth Bore Weld Plate Mount

Fig. 201 - Smooth Bore Hang Plate Mount

Fig. 202 - Smooth Bore Base Plate Mount

Fig. 203 - Smooth Bore RAL-1 Rail Mounting

Fig. 204 - Smooth Bore Stacking Kit

Fig. 211 - Smooth Bore Unistrut Mount

Fig. 221 - Smooth Bore Rod Mount

Page 19

Page 20

Page 21

Page 22

Page 23

Page 24

Page 25



Miscellaneous

Technical Data Material Properties,
Slope Conversion Chart, Shear Force Diagram

Page 26-30

BEHRINGER[®]

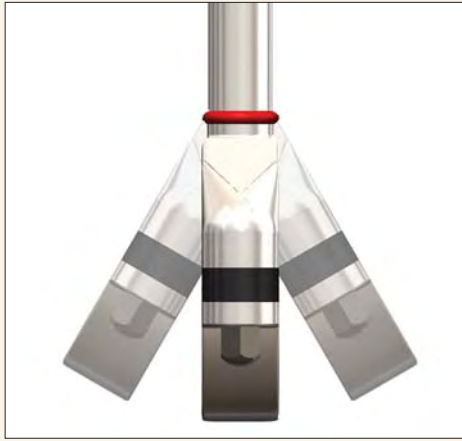

Automatic Slope Adjustment

Tension Ring connection allows hanger body to adjust 7° to tube slope and rotate 360° to relieve all unnecessary stresses between tube and “CH” support

Telescopic - Elevation Adjustment

CH Series with Stanchion allows for quick x, y and z axis adjustment for ease in locating tube's direction, elevation and slope.

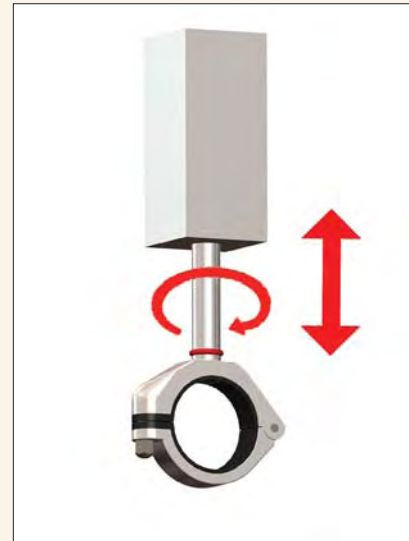

One Piece unit

Assembled as a one piece unit. No loose parts, quick identification and swift installation. Acorn bolt and plastics are captive to the “CH” Housing. (except in Group 9)

Lot Traceability

Behringer has lot traceability and material identification for all stainless steel products. (exact locations will vary)



EXAMPLE ORDERING GUIDE

CH Part # Configurator

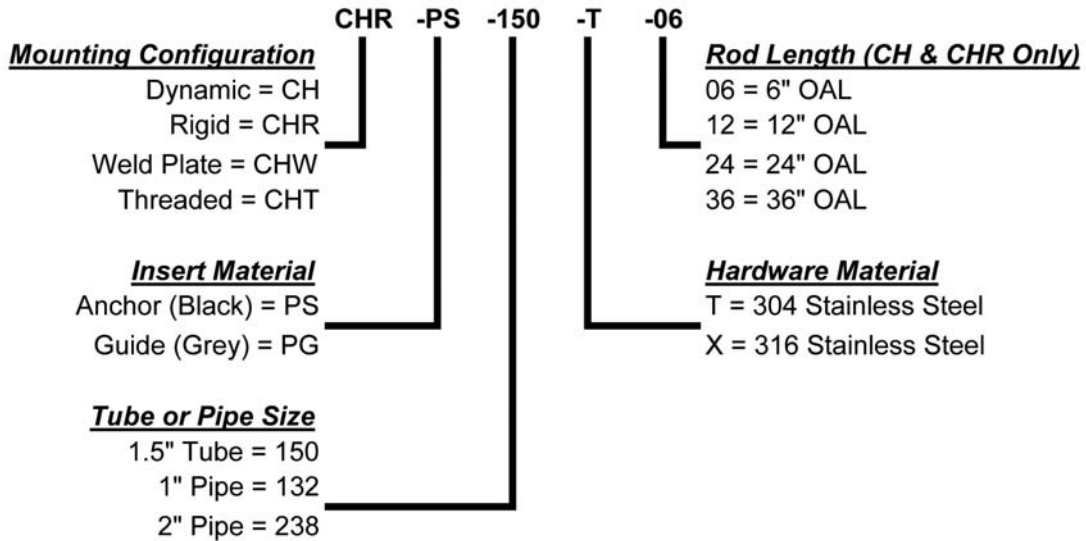

Smooth Bore Part # Configurator

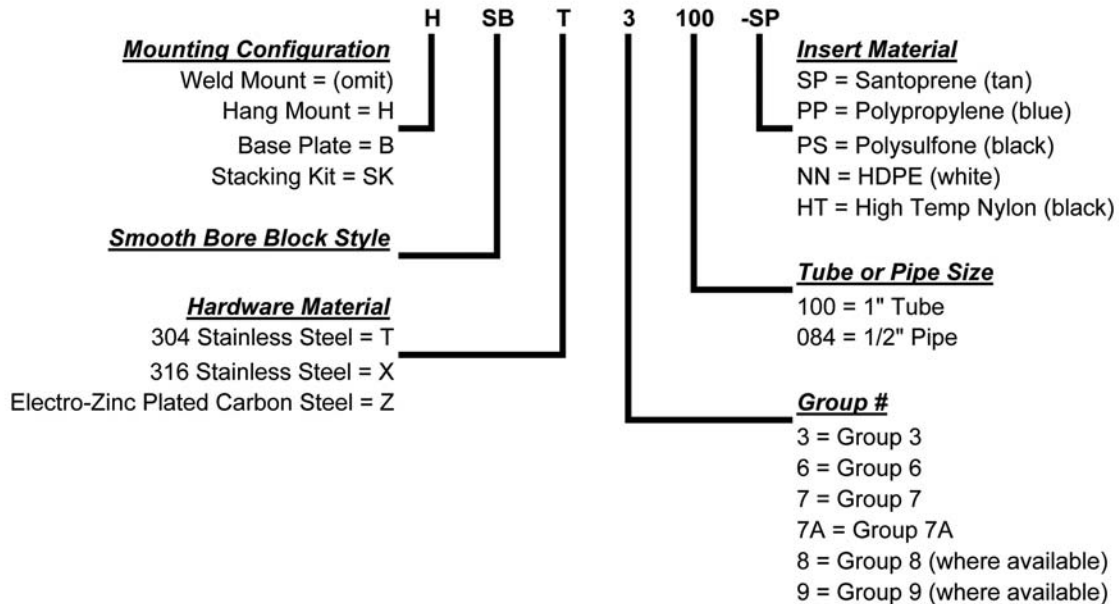

BEHRINGER®

FIG. 221 CH

DYNAMIC MOUNT HANGER

Dynamic "Anchor or Guide" Slope Adjusting Hanger / Rod Mount Unit

One piece unit with attached dynamic rod. Hanger rods are available in lengths ranging from min of 1.26" to 96". Standard length is 6".

Features: A dynamic union between the hanger rod and hanger housing allows for the housing to self adjust to the tube's slope for drainability as well as a 360° swivel. A 6" rod is the standard length with other lengths available. Fig 221 CH can also be used in combination with the figure 223, 225 or 226 stanchions. This combination will allow the support to be adjusted telescopically to the tube or pipe elevation. Call customer service for the price and availability of special rod lengths.

Size Range: 0.24" diameters through 6.00" diameter covering imperial tube, pipe and copper sizes. ISO and DIN standards, and special diameters available upon request.

Hardware: 304 Stainless Steel (Standard), 316 Stainless Steel

Finish: Stainless Steel at a 25 RA

Plastic: Polysulfone (Black = Anchor and Gray = Guide)

Shearing: Anchors - Refer to shear force diagram in technical section (page 29)
 Guides - Allows free axial movement for thermal expansion of tube or pipe



Housing with Black inserts are "Anchor" supports



Housing with Gray inserts are "Guide" supports

Fig. 221CH Compact Dynamic Hanger - Part Number Configurator

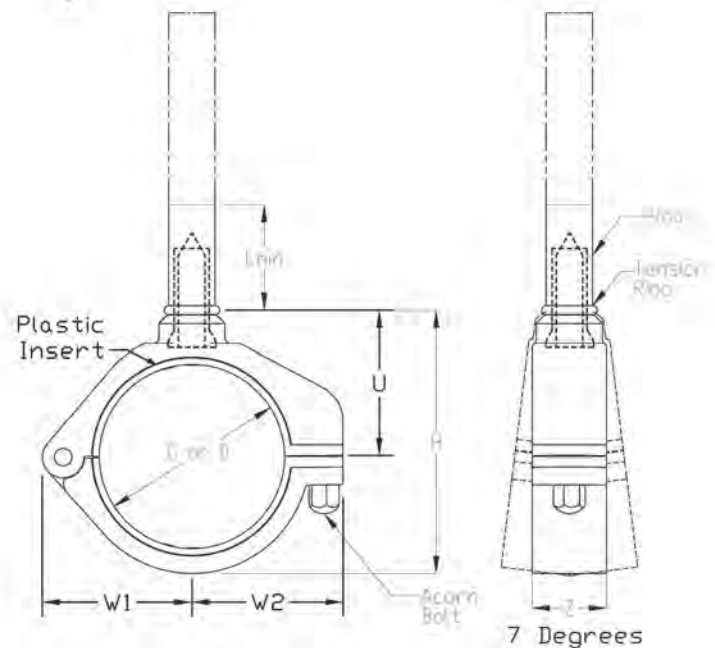
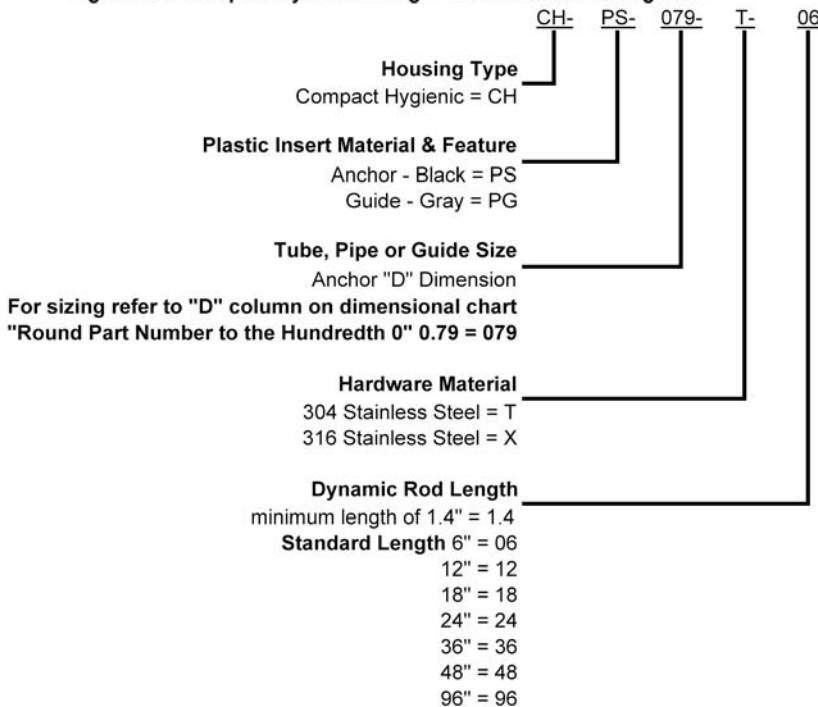

FIG. 221 CH

DYNAMIC MOUNT HANGER

Group No.	Stainless Tube	Pipe	Copper Tube	221 CH		UNIVERSAL DIMENSIONS AMONG HOUSINGS				221 CH				
				Part Number (-PS- as displayed is an Anchor & -PG- would make a Guide)	"D" Anchor Plastic	"G" Guide Plastic	Dimension, in. (mm)							Weight, lb (kg)
							W1	W2	Z	L, min	U	H	Rod Diameter	
1	6 mm			CH-PS-024-T-??	0.24	0.27	0.93 (24)	1.02 (26)	0.75 (19)	1.26 (32)	0.95 (24)	1.54 (39)	0.63 (16)	0.76 (0.34)
	1/4"			CH-PS-025-T-??	0.25	0.29								
	3/8"			CH-PS-038-T-??	0.38	0.40								
	1/2"			CH-PS-050-T-??	0.50	0.54								
2		1/4"		CH-PS-054-T-??	0.54	0.58	1.06 (27)	1.15 (29)	0.75 (19)	1.26 (32)	1.07 (27)	1.77 (45)	0.63 (16)	0.79 (0.36)
			1/2"	CH-PS-063-T-??	0.63	0.67								
			3/4"	CH-PS-075-T-??	0.75	0.79								
3	20 mm			CH-PS-079-T-??	0.79	0.82	1.20 (31)	1.28 (33)	0.75 (19)	1.26 (32)	1.20 (30)	2.04 (52)	0.63 (16)	0.82 (0.37)
		1/2"		CH-PS-084-T-??	0.84	0.88								
			3/4"	CH-PS-088-T-??	0.88	0.91								
			1"	CH-PS-100-T-??	1.00	1.04								
4		3/4"		CH-PS-105-T-??	1.05	1.09	1.45 (37)	1.56 (40)	0.75 (19)	1.26 (32)	1.45 (39)	2.53 (65)	0.63 (16)	0.86 (0.39)
			1"	CH-PS-113-T-??	1.13	1.16								
			1"	CH-PS-132-T-??	1.32	1.35								
			1 1/2"	CH-PS-150-T-??	1.50	1.54								
5	40 mm			CH-PS-158-T-??	1.58	1.61	1.74 (44)	1.79 (46)	0.75 (19)	1.26 (32)	1.70 (43)	3.03 (77)	0.63 (16)	0.97 (0.44)
			1 1/2"	CH-PS-163-T-??	1.63	1.66								
			1 1/2"	CH-PS-190-T-??	1.90	1.94								
			2"	CH-PS-200-T-??	2.00	2.04								
6	52 mm			CH-PS-205-T-??	2.05	2.10	2.02 (51)	2.04 (52)	1.00 (25)	1.36 (35)	2.04 (52)	3.63 (92)	0.75 (19)	1.37 (0.62)
			2"	CH-PS-213-T-??	2.13	2.18								
			2"	CH-PS-238-T-??	2.38	2.43								
			2 1/2"	CH-PS-250-T-??	2.50	2.55								
7	70 mm			CH-PS-276-T-??	2.76	2.81	2.27 (58)	2.29 (58)	1.00 (25)	1.36 (35)	2.29 (58)	4.13 (105)	0.75 (19)	1.42 (0.64)
		2 1/2"		CH-PS-288-T-??	2.88	2.93								
			3"	CH-PS-300-T-??	3.00	3.05								
8			3"	CH-PS-313-T-??	3.13	3.18	2.76 (70)	2.79 (71)	1.00 (25)	1.36 (35)	2.79 (71)	5.13 (131)	0.75 (19)	1.62 (0.73)
			3"	CH-PS-350-T-??	3.50	3.55								
			4"	CH-PS-400-T-??	4.00	4.05								
8A	104 mm			CH-PS-409-T-??	4.09	4.14	3.00 (76)	3.09 (78)	1.00 (25)	1.36 (35)	3.04 (77)	5.63 (143)	0.75 (19)	1.72 (0.78)
			4"	CH-PS-413-T-??	4.13	4.18								
			4"	CH-PS-450-T-??	4.50	4.55								
9	129 mm			CH-PS-508-T-??	5.08	5.13	3.98 (101)	4.46 (113)	1.50 (38)	1.78 (45)	4.16 (106)	7.74 (197)	1.00 (25)	5.33 (2.42)
		6"		CH-PS-600-T-??	6.00	6.05								

All standard sizes shown, special diameters available upon request

FIG. 221 CHR

RIGID MOUNT HANGER

Rigid "Anchor or Guide" Hanger / Rod Mount Unit



Housing with Black inserts are "Anchor" supports

One piece unit with rod welded to the hanger housing. Hanger rods are available in lengths up to 96". Standard rod length is 6"

Features: The rigid hanger is ideal for supporting vertical runs and reducing vibrations. This type rod connection does not offer the dynamic slope adjustment. 6" rod is the standard length with other lengths available. Fig 221 CHR can also be used in combination with the figure 223, 225 or 226 stanchions. This combination will allow the support to be adjusted telescopically to the tube or pipe elevation. Call customer service for the price and availability of special rod lengths.

Size Range: 0.24" diameters through 6.00" diameter covering imperial tube, pipe and copper sizes. ISO and DIN standards, and special diameters available upon request.

Hardware: 304 Stainless Steel (Standard), 316 Stainless Steel

Finish: Stainless steel at a 25 RA

Plastic: Polysulfone (Black = Anchor and Gray = Guide)

Shearing: Anchors - Refer to shear force diagram in technical section (page 29)

Guides - Allows free axial movement for thermal expansion of tube or pipe



Housing with Gray inserts are "Guide" supports

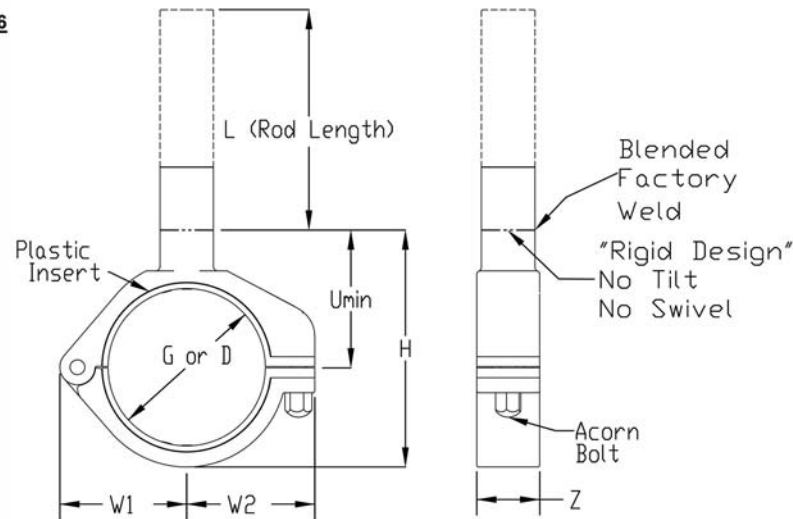
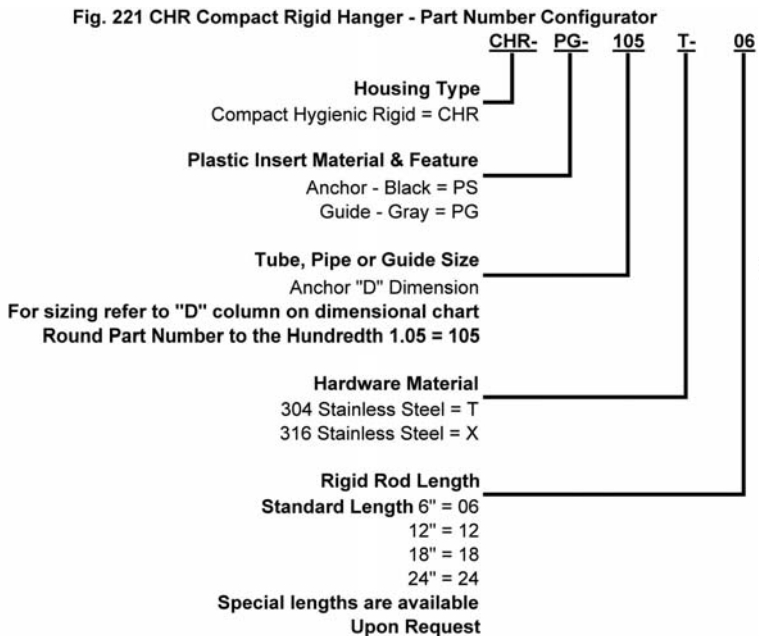

FIG. 221 CHR

RIGID MOUNT HANGER

Group No.	Stainless Tube	Pipe	Copper Tube	221 CHR		UNIVERSAL DIMENSIONS AMONG HOUSINGS						221 CHR		
				Part Number (-PS- as displayed is an Anchor & -PG- would make a Guide)	"D" Anchor Plastic	"G" Guide Plastic	Dimension, in. (mm)						Rod Diameter	Weights lb (kg)
							W1	W2	Z	U (min)	H	L		
1	6 mm			CHR-PS-024-T-??	0.24	0.27	0.93 (24)	1.02 (26)	0.75 (19)	1.08 (28)	1.67 (42)	??	1/2" (12)	0.58 (0.26)
	1/4"			CHR-PS-025-T-??	0.25	0.29								
	3/8"			CHR-PS-038-T-??	0.38	0.40								
	1/2"			CHR-PS-050-T-??	0.50	0.54								
2		1/4"		CHR-PS-054-T-??	0.54	0.58	1.06 (27)	1.15 (29)	0.75 (19)	1.23 (31)	1.93 (49)	??	1/2" (12)	0.60 (0.27)
			1/2"	CHR-PS-063-T-??	0.63	0.67								
			3/4"	CHR-PS-075-T-??	0.75	0.79								
3	20 mm			CHR-PS-079-T-??	0.79	0.82	1.20 (31)	1.28 (33)	0.75 (19)	1.35 (34)	2.19 (56)	??	1/2" (12)	0.66 (0.30)
			1/2"	CHR-PS-084-T-??	0.84	0.88								
			3/4"	CHR-PS-088-T-??	0.88	0.91								
			1"	CHR-PS-100-T-??	1.00	1.04								
4			3/4"	CHR-PS-105-T-??	1.05	1.09	1.45 (37)	1.56 (40)	0.75 (19)	1.66 (42)	2.74 (69)	??	1/2" (12)	0.72 (0.33)
			1"	CHR-PS-113-T-??	1.13	1.16								
			1"	CHR-PS-132-T-??	1.32	1.35								
			1 1/2"	CHR-PS-150-T-??	1.50	1.54								
5	40 mm			CHR-PS-158-T-??	1.58	1.61	1.74 (44)	1.79 (46)	0.75 (19)	1.85 (47)	3.18 (81)	??	1/2" (12)	0.80 (0.36)
			1 1/2"	CHR-PS-163-T-??	1.63	1.66								
			1 1/2"	CHR-PS-190-T-??	1.90	1.94								
			2"	CHR-PS-200-T-??	2.00	2.04								
6	52 mm			CHR-PS-205-T-??	2.05	2.10	2.02 (51)	2.04 (52)	1.00 (25)	2.18 (55)	3.77 (96)	??	5/8" (19)	1.61 (0.73)
			2"	CHR-PS-213-T-??	2.13	2.18								
			2"	CHR-PS-238-T-??	2.38	2.43								
			2 1/2"	CHR-PS-250-T-??	2.50	2.55								
7	70 mm			CHR-PS-276-T-??	2.76	2.81	2.27 (58)	2.29 (58)	1.00 (25)	2.34 (59)	4.18 (106)	??	5/8" (19)	1.67 (0.73)
			2 1/2"	CHR-PS-288-T-??	2.88	2.93								
			3"	CHR-PS-300-T-??	3.00	3.05								
8			3"	CHR-PS-313-T-??	3.13	3.18	2.76 (70)	2.79 (71)	1.00 (25)	3.08 (78)	5.42 (137)	??	3/4" (19)	1.86 (0.84)
			3"	CHR-PS-350-T-??	3.50	3.55								
			4"	CHR-PS-400-T-??	4.00	4.05								
8A	104 mm			CHR-PS-409-T-??	4.09	4.14	3.01 (76)	3.09 (78)	1.00 (25)	3.28 (83)	5.87 (149)	??	3/4" (19)	1.88 (0.85)
			4"	CHR-PS-413-T-??	4.13	4.18								
			4"	CHR-PS-450-T-??	4.50	4.55								
9	129 mm			CHR-PS-508-T-??	5.08	5.13	3.98 (101)	4.46 (113)	1.50 (38)	4.45 (113)	8.03 (204)	??	1" (25)	6.21 (2.81)
			6"	CHR-PS-600-T-??	6.00	6.05								

All standard sizes shown, special diameters available upon request

Rigid "Anchor or Guide" Support with Weld Plate

One piece unit with weld plate attached to hanger housing.



Housing with Black inserts are "Anchor" supports



Housing with Gray inserts are "Guide" supports

Features: Compact housing is mounted on a weld plate. This type of mounting configuration does not offer the dynamic slope adjustment feature. The CHW hanger is ideal for supporting vertical runs and reducing vibrations.

Size Range: 0.24" diameters through 6.00" diameter covering imperial tube, pipe and copper sizes. ISO and DIN standards and special diameters available upon request.

Hardware: 304 Stainless Steel (Standard), 316 Stainless Steel

Finish: Stainless Steel at a 25 RA

Plastic: Polysulfone (Black = Anchor and Gray = Guide)

Shearing: Anchors - Refer to shear force diagram in technical section (page 29)

Guides - Allows free axial movement for thermal expansion of tube or pipe

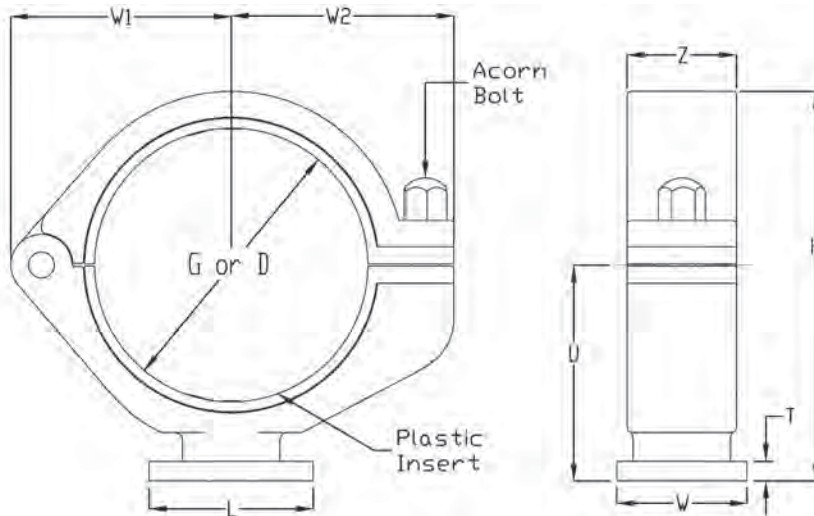

Fig. 221 CHW Weld Plate Mount Support - Part Number Configurator

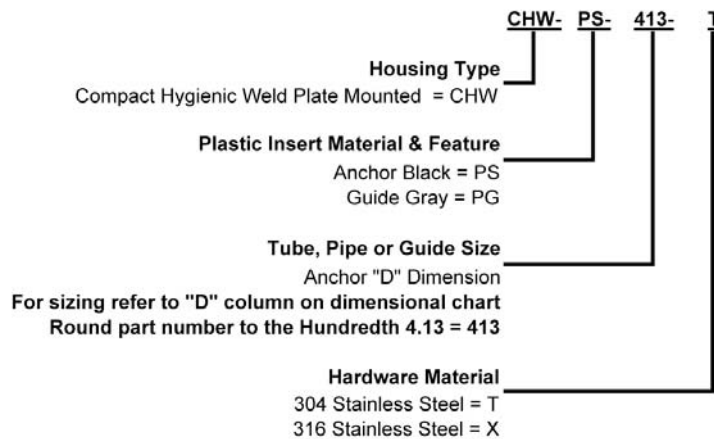

FIG. 221CHW

WELD PLATE MOUNT SUPPORT

Group No.	Stainless Tube	Pipe	Copper Tube	221 CHW	UNIVERSAL DIMENSIONS AMONG HOUSINGS				221 CHW					Weights, lb (kg)	
				Part Number (-PS- as displayed is an Anchor & -PG- would make a Guide)	"D" Anchor Plastic	"C" Guide Plastic	Dimension, in. (mm)								
							W1	W2	Z	U	H	T	L		W
1	6 mm			CHW-PS-024-T	0.24	0.27									
	1/4"			CHW-PS-025-T	0.25	0.29	0.93 (24)	1.02 (26)	0.75 (19)	1.17 (30)	1.76 (45)	3/16" (4.7)	1.50 (38)	1.50 (38)	0.37 (0.17)
	3/8"			CHW-PS-038-T	0.38	0.40									
	1/2"			CHW-PS-050-T	0.50	0.54									
2		1/4"		CHW-PS-054-T	0.54	0.58									
			1/2"	CHW-PS-063-T	0.63	0.67	1.06 (27)	1.15 (29)	0.75 (19)	1.32 (33)	2.02 (51)	3/16" (4.7)	1.50 (38)	1.50 (38)	0.39 (0.18)
			3/4"	CHW-PS-075-T	0.75	0.79									
3	20 mm			CHW-PS-079-T	0.79	0.82									
		1/2"		CHW-PS-084-T	0.84	0.88	1.20 (31)	1.28 (33)	0.75 (19)	1.44 (37)	2.28 (58)	3/16" (4.7)	1.50 (38)	1.50 (38)	0.44 (0.20)
			3/4"	CHW-PS-088-T	0.88	0.91									
			1"	CHW-PS-100-T	1.00	1.04									
4		3/4"		CHW-PS-105-T	1.05	1.09									
			1"	CHW-PS-113-T	1.13	1.16	1.45 (37)	1.56 (39)	0.75 (19)	1.75 (44)	2.83 (72)	3/16" (4.7)	1.75 (44)	1.75 (44)	0.56 (0.25)
			1"	CHW-PS-132-T	1.32	1.35									
			1 1/2"	CHW-PS-150-T	1.50	1.54									
5	40 mm			CHW-PS-158-T	1.58	1.61									
			1 1/2"	CHW-PS-163-T	1.63	1.66	1.74 (44)	1.79 (46)	0.75 (19)	1.94 (49)	3.27 (83)	3/16" (4.7)	1.75 (44)	1.75 (44)	0.63 (0.28)
			1 1/2"	CHW-PS-190-T	1.90	1.94									
			2"	CHW-PS-200-T	2.00	2.04									
6	52 mm			CHW-PS-205-T	2.05	2.10									
			2"	CHW-PS-213-T	2.13	2.18	2.02 (51)	2.04 (52)	1.00 (25)	2.27 (58)	3.86 (98)	3/16" (4.7)	2.50 (64)	1.75 (44)	0.90 (0.41)
			2"	CHW-PS-238-T	2.38	2.43									
			2 1/2"	CHW-PS-250-T	2.50	2.55									
7	70 mm			CHW-PS-276-T	2.76	2.81									
			2 1/2"	CHW-PS-288-T	2.88	2.93	2.27 (58)	2.29 (58)	1.00 (25)	2.43 (62)	4.27 (108)	3/16" (4.7)	2.50 (64)	1.75 (44)	0.96 (0.43)
			3"	CHW-PS-300-T	3.00	3.05									
8			3"	CHW-PS-313-T	3.13	3.18									
			3"	CHW-PS-350-T	3.50	3.55	2.76 (70)	2.79 (71)	1.00 (25)	3.17 (81)	5.51 (140)	3/16" (4.7)	2.50 (64)	1.75 (44)	1.15 (0.52)
			4"	CHW-PS-400-T	4.00	4.05									
8A	104 mm			CHW-PS-409-T	4.09	4.14									
			4"	CHW-PS-413-T	4.13	4.18	3.00 (76)	3.09 (78)	1.00 (25.4)	3.37 (86)	5.96 (151)	3/16" (4.7)	2.50 (64)	1.75 (44)	1.17 (0.53)
			4"	CHW-PS-450-T	4.50	4.55									
9	129 mm			CHW-PS-508-T	5.08	5.13	3.98 (101)	4.46 (113)	1.50 (38)	4.54 (115)	8.12 (206)	1/4" (6.4)	4.00 (108)	1.75 (44)	4.67 (2.12)
			6"	CHW-PS-600-T	6.00	6.05									

All standard sizes shown, special diameters available upon request

FIG. 221 CHT

THREADED MOUNT HANGER

Threaded Anchor or Guide Hanger

One piece unit with threaded adaptor. **Rod is sold separately.**



Housing with Black inserts are "Anchor" supports

Features: The threaded mounting section, on top of housing, doubles as a threaded rod connector and a welding platform. This type rod connection does not offer the dynamic slope adjustment feature. Figure 221 CHT, with a rod, can also be used in combination with the figure 223, 225 or 226 stan-chions. This combination will allow the support to be adjusted telescopically to the tube or pipe elevation. Call customer service for the price and availability of special rod lengths.



Housing with Gray inserts are "Guide" supports

Size Range: 0.24" diameters through 6.00" diameter covering imperial tube, pipe and copper sizes. ISO and DIN standards, and special diameters available upon request.

Hardware: 304 Stainless Steel (Standard), 316 Stainless Steel

Finish: Stainless steel at a 25 RA

Plastic: Polysulfone (Black = Anchor and Gray = Guide)

Shearing: Anchors - Refer to shear force diagram in technical section (page 29)

Guides - Allows free axial movement for thermal expansion of tube or pipe

Fig. 221 CHT Compact Threaded Mount Hanger - Part Number Configurator

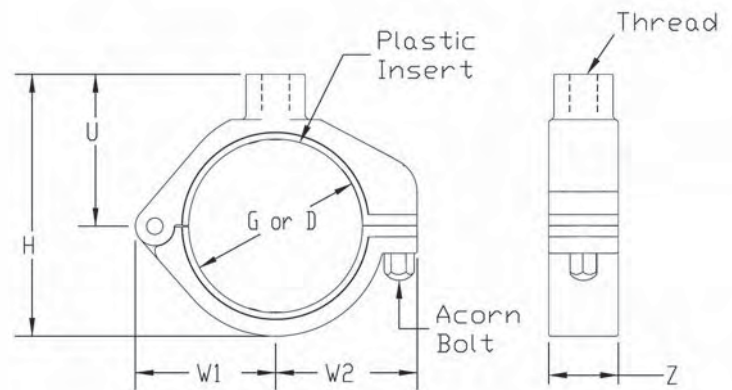
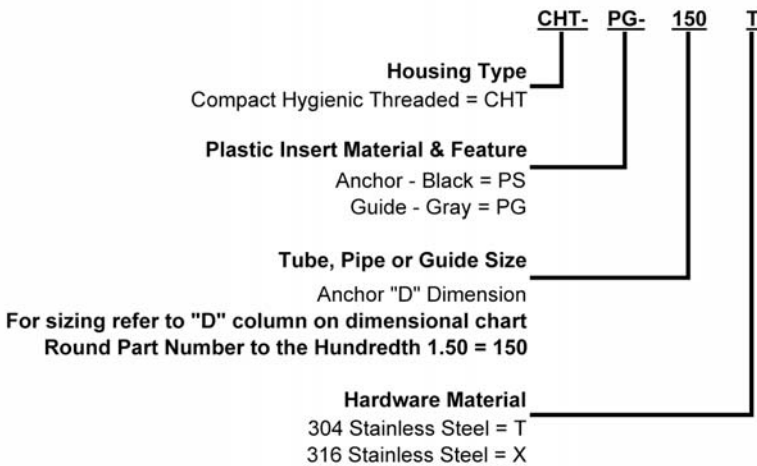

****See Figure 245 to Order Threaded Rod Separately****

FIG. 221 CHT

THREADED MOUNT HANGER

Group No.	Stainless Tube	Pipe	Copper Tube	221 CHT		UNIVERSAL DIMENSIONS AMONG HOUSINGS						221 CHT			
				Part Number (-PS- as displayed is an Anchor & -PG- would make a Guide)	"D" Anchor Plastic	"G" Guide Plastic	Dimension, in. (mm)						Rod Diameter (Sold Separately)	Weights lb (kg)	
							W1	W2	Z	U	H	Thread			
1	6 mm			CHT-PS-024-T	0.24	0.27									
	1/4"			CHT-PS-025-T	0.25	0.29	0.93 (24)	1.02 (26)	0.75 (19)	1.08 (28)	1.67 (42)	5/16"-18 (10)	1/2" (12)	B	0.26 (0.12)
	3/8"			CHT-PS-038-T	0.38	0.40									
	1/2"			CHT-PS-050-T	0.50	0.54									
2		1/4"		CHT-PS-054-T	0.54	0.58									
			1/2"	CHT-PS-063-T	0.63	0.67	1.06 (27)	1.15 (29)	0.75 (19)	1.23 (31)	1.93 (49)	5/16"-18 (10)	1/2" (12)	B	0.28 (0.13)
			3/4"	CHT-PS-075-T	0.75	0.79									
3	20 mm			CHT-PS-079-T	0.79	0.82									
		1/2"		CHT-PS-084-T	0.84	0.88	1.20 (31)	1.28 (33)	0.75 (19)	1.35 (34)	2.19 (56)	5/16"-18 (10)	1/2" (12)	B	0.33 (0.15)
			3/4"	CHT-PS-088-T	0.88	0.91									
			1"	CHT-PS-100-T	1.00	1.04									
4		3/4"		CHT-PS-105-T	1.05	1.09									
			1"	CHT-PS-113-T	1.13	1.16	1.46 (37)	1.56 (40)	0.75 (19)	1.66 (42)	2.74 (69)	5/16"-18 (10)	1/2" (12)	B	0.40 (0.18)
			1"	CHT-PS-132-T	1.32	1.35									
			1 1/2"	CHT-PS-150-T	1.50	1.54									
5	40 mm			CHT-PS-158-T	1.58	1.61									
			1 1/2"	CHT-PS-163-T	1.63	1.66	1.74 (44)	1.79 (46)	0.75 (19)	1.85 (47)	3.18 (81)	5/16"-18 (10)	1/2" (12)	B	0.48 (0.22)
			1 1/2"	CHT-PS-190-T	1.90	1.94									
			2"	CHT-PS-200-T	2.00	2.04									
6	52 mm			CHT-PS-205-T	2.05	2.10									
			2"	CHT-PS-213-T	2.13	2.18	2.02 (51)	2.04 (52)	1.00 (25)	2.18 (55)	3.77 (96)	3/8"-16 (10)	5/8" (19)	C	0.70 (0.32)
			2"	CHT-PS-238-T	2.38	2.93									
			2 1/2"	CHT-PS-250-T	2.50	2.55									
7	70 mm			CHT-PS-276-T	2.76	2.81									
			2 1/2"	CHT-PS-288-T	2.88	2.93	2.27 (58)	2.29 (58)	1.00 (25)	2.34 (59)	4.18 (106)	3/8"-16 (10)	5/8" (19)	C	0.76 (0.34)
			3"	CHT-PS-300-T	3.00	3.05									
8			3"	CHT-PS-313-T	3.13	3.18									
			3"	CHT-PS-350-T	3.50	3.55	2.76 (70)	2.79 (71)	1.00 (25)	3.08 (78)	5.42 (137)	1/2"-13 (16)	3/4" (19)	D	0.95 (0.43)
			4"	CHT-PS-400-T	4.00	4.05									
8A	104 mm			CHT-PS-409-T	4.09	4.14									
			4"	CHT-PS-413-T	4.13	4.18	3.00 (76)	3.09 (78)	1.00 (25.4)	3.28 (83)	5.87 (149)	1/2"-13 (16)	3/4" (19)	D	0.97 (0.44)
			4"	CHT-PS-450-T	4.50	4.55									
9	129 mm			CHT-PS-508-T	5.08	5.13	3.98 (101)	4.46 (113)	1.50 (38)	4.46 (113)	8.04 (204)	3/4"-10 (20)	1" (25)	E	4.20 (1.90)
			6"	CHT-PS-600-T	6.00	6.05									

All standard sizes shown, special diameters available upon request

FIG. 245

THREADED SUPPORT ROD

Size Range: 3/8" outside diameter to 1" outside diameter with different rod lengths and connection threads available.

Hardware: 304 Stainless Steel or 316 Stainless Steel; Carbon or Electro-Zinc Plated Carbon Steel

Finish: 25 Ra (for 304/316); Other available upon request

Ordering: To identify the proper thread refer to the "T" column on Fig. 221CHT or the Hang Nut column on Fig. 201. Then use the Fig 245 part number configurator located at the bottom of this page.

Installations: Thread the rod into housing. Cut the rod in the field to proper length. Field weld the rod to support structure. The rod can also be used in combination with the figure 223, 225 or 226 stanchions. This combination will allow the support to be adjusted telescopically to the tube or pipe elevation.

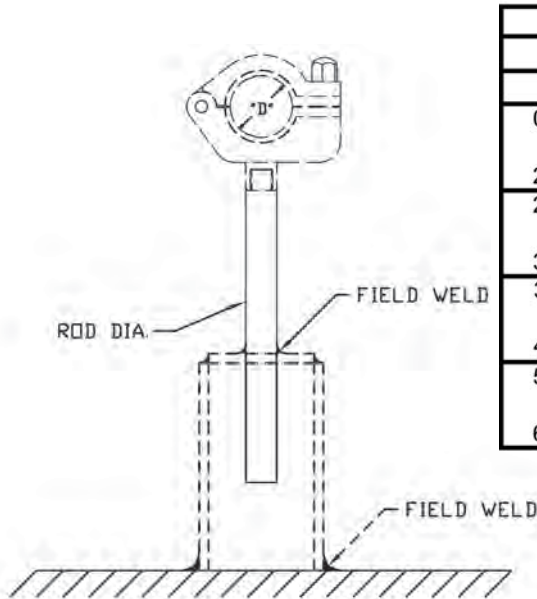

Fig. 225 Telescopic Rod Adjustment to the tubes elevation

CH Series		SB or Block Style	
Fig. 221CHT		Fig. 201	
OD	Thread	OD	Thread
0.24" to 2.00"	5/16"- 18 (031)	0.25 to 4.5	3/8"-16 (038)
2.05" to 3.00"	3/8"- 16 (038)	N/A	N/A
3.13" to 4.50"	1/2"- 13 (050)	6.00" to 6.625"	5/8"-11 (063)
5.08" to 6.00"	3/4"- 10 (075)	N/A	N/A

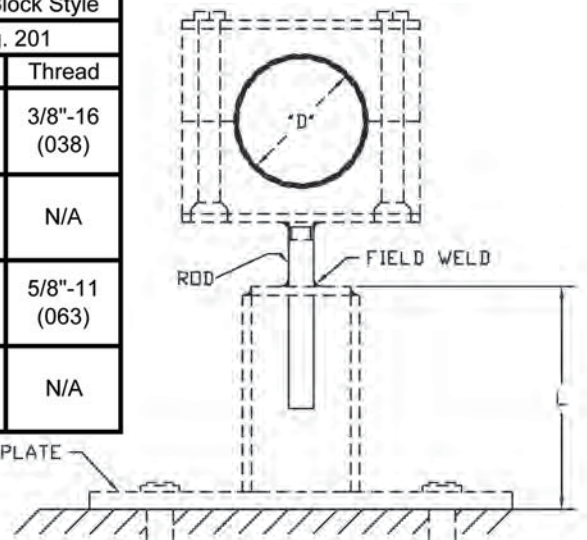
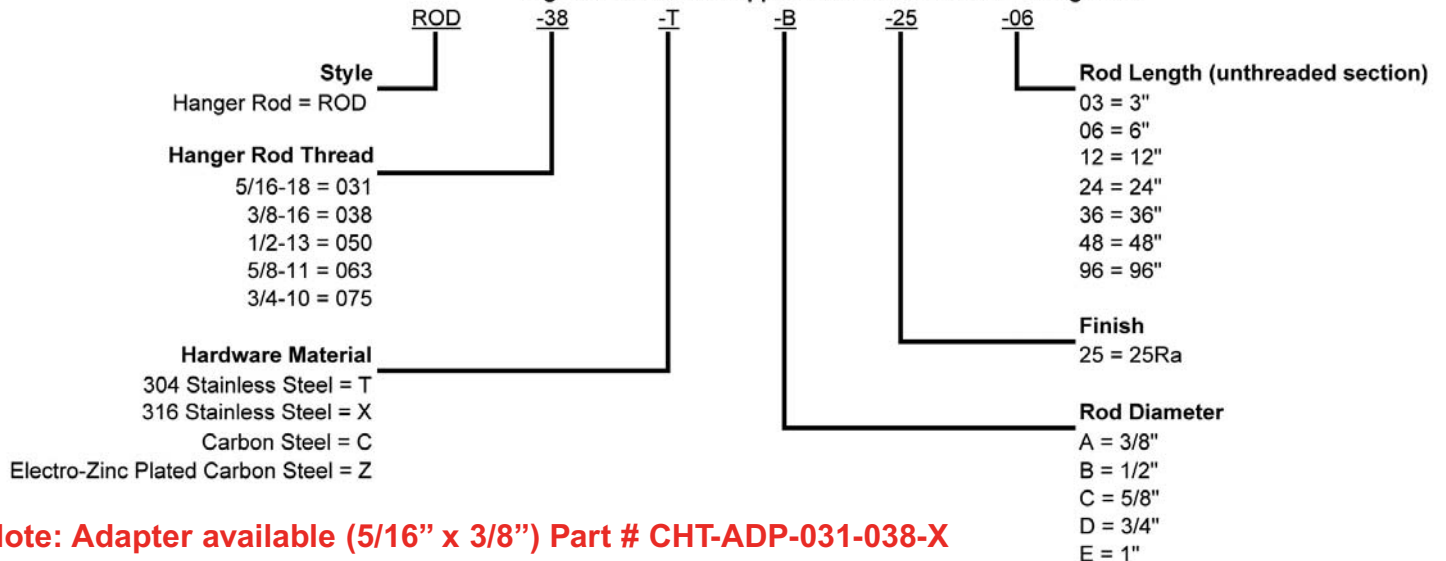

Fig. 226 Telescopic Rod Adjustment to the tubes elevation

Fig. 245 Threaded Support Rod - Part Number Configurator



Note: Adapter available (5/16" x 3/8") Part # CHT-ADP-031-038-X

FIG. 223

TELESCOPIC ADJUSTING ROUND FLOOR MOUNT STAND

The Telescopic Adjusting Round Floor Mount Stand allows the housing's rod elevation to be adjusted up to 2" from the base plate's surface. The rod attached to the housing slides inside the base plate's elevation adjustment tube (.560 ID x .750 OD). This fine tune adjustment allows the installer to quickly change the support's elevation to match the tube's distance from the floor. The base plate can be supplied with or without anchor bolt holes. Anchor bolts not supplied by Behringer.



Base Plate Sizing: RSP1 & RSP2 - 0.25" to 2.00" OD tube & pipe sizes
 RSP3 & RSP4 - 2.05" to 4.50" OD tube & pipe sizes
 RSP5 & RSP6 - 5.08" to 6.00" OD tube & pipe sizes

Hardware: 304 Stainless Steel, 316 Stainless Steel, Carbon Steel & Electro-Zinc Plated Carbon Steel

Finish: MILL = Fabricated steel and welds are a mill finish
 BUFF = Fabricated steel and weld are buffed to remove splatter
 BLND = Fabricated steel is polished and welds are blended
 Special finishes and painted stands are available, call Behringer Customer Service for price and availability.

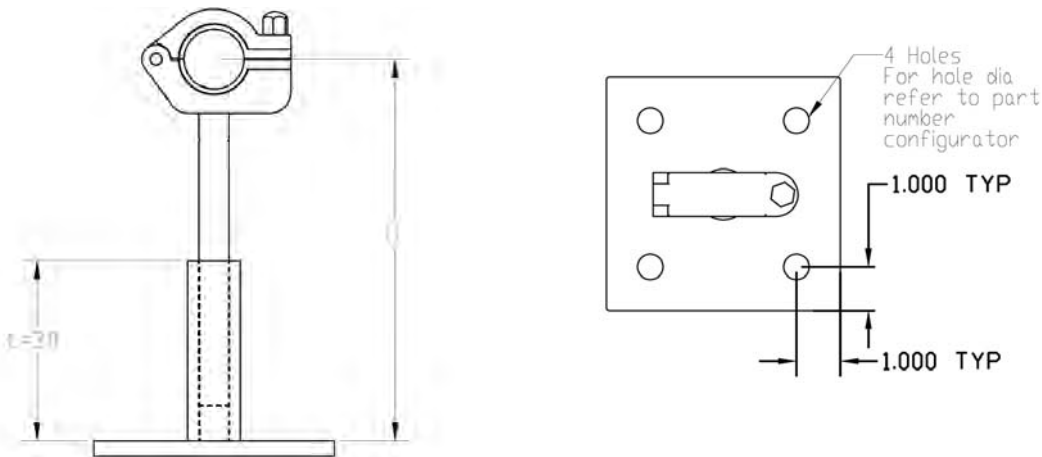

Clamp & Rod Sold Separately

Fig. 223 Telescopic Adjusting Round Floor Mount Stand

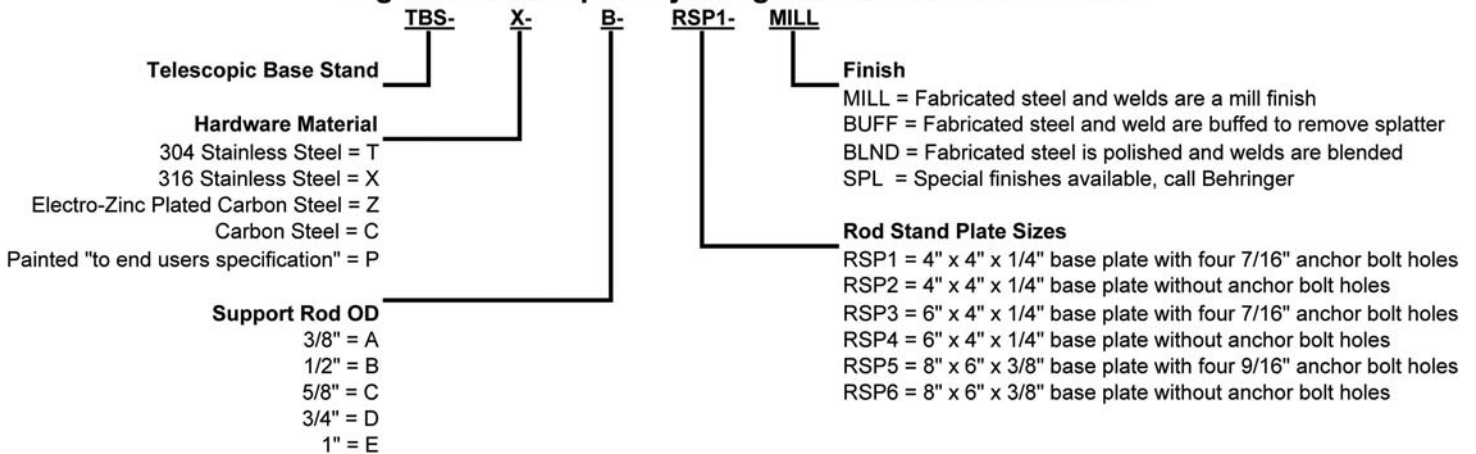

FIG. 224

CH SERIES ROD STAND PLATE



One piece CH Series Rod Stand Plate with rod cut to specified length. The rod is welded to the base plate, which can be supplied with or without anchor bolt-holes. Anchor bolts not supplied by Behringer.

The height is calculated from the top of the plate to centerline of tube or pipe. Please refer to "U" min column in catalog for minimum height of the required RH series product.

Base Plate Sizing: RSP1 & RSP2 - 0.25" to 2.00" OD tube & pipe sizes
 RSP3 & RSP4 - 2.05" to 4.50" OD tube & pipe sizes
 RSP5 & RSP6 - 5.08" to 6.00" OD tube & pipe sizes

Hardware: 304 Stainless Steel, 316 Stainless Steel

Finish: MILL = Fabricated steel and welds are a mill finish
 BUFF = Fabricated steel and weld are buffed to remove splatter
 BLND = Fabricated steel is polished and welds are blended
 Special finishes and painted stands are available, call Behringer Customer Service for price and availability.

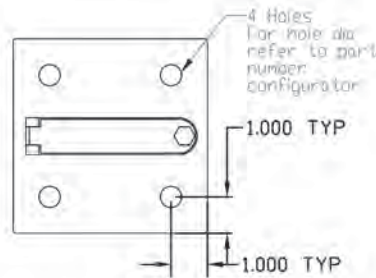
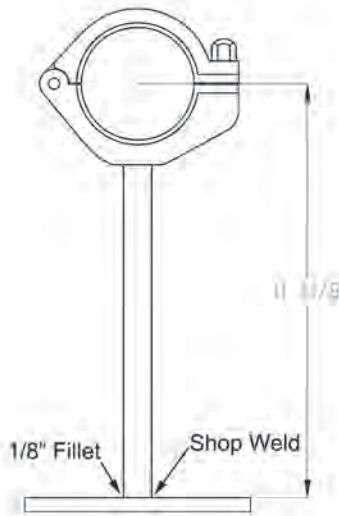

Fig. 224 CH Series Rod Stand Plate - Part Number Configurator

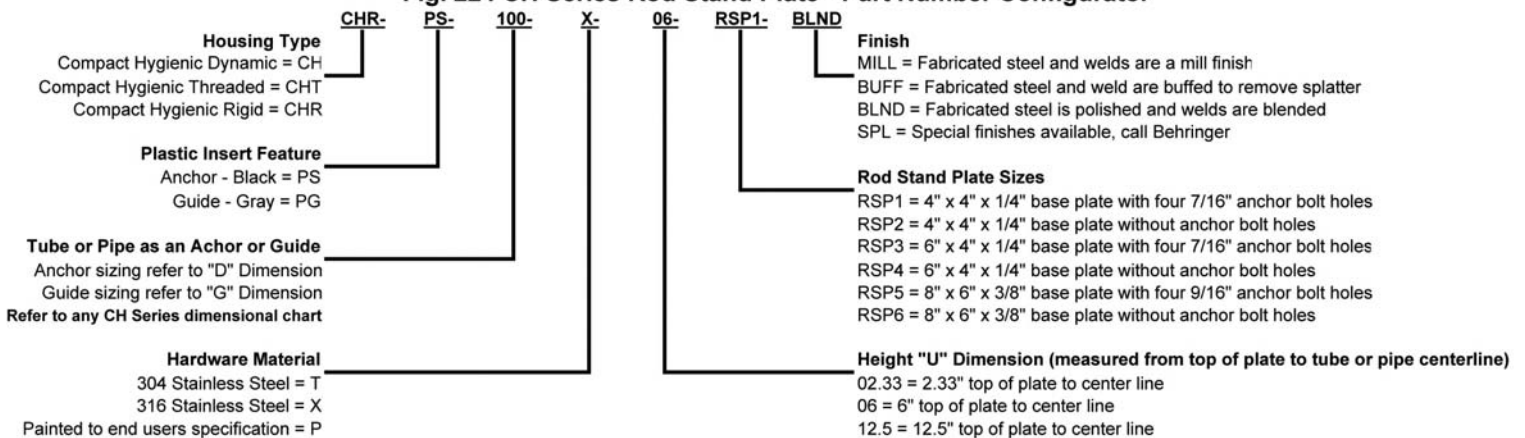

FIG. 225

TELESCOPIC ADJUSTING STANCHION - HANG MOUNT

Hanger Stanchion with square or round tube cut to specified length. One end of the tube has a capped end with a rod hole. The rod hole is used for telescopic adjustment of the hanger rod. Specify the steel finish and the finish on the weld.



Features: Hole in capped end of tube allows the hanger rod to be manually adjusted for telescopic location of the tube or pipe.

Hardware: 304 Stainless Steel; 316 Stainless Steel, Carbon Steel & Electro-Zinc Plated Carbon Steel

Finish: MILL = Fabricated steel and welds are a mill finish
 BUFF = Fabricated steel and welds are buffed to remove splatter
 BLND = Fabricated steel is polished and welds are blended
 Special finishes and painted stanchions are available, call Behringer Customer Service for price and availability.

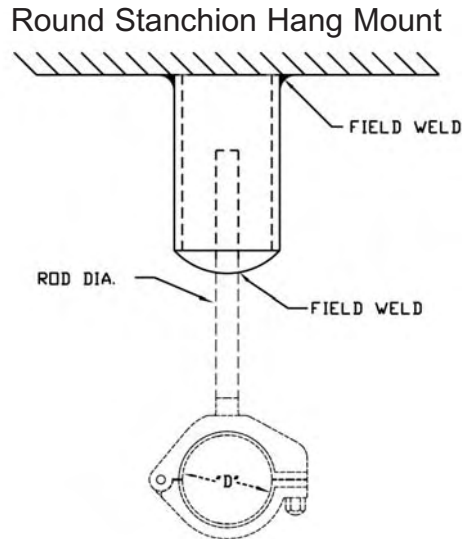
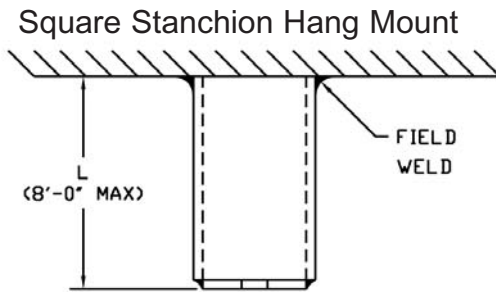

Fig 225 Telescopic Hang Mount Stanchion - Part Number Configurator

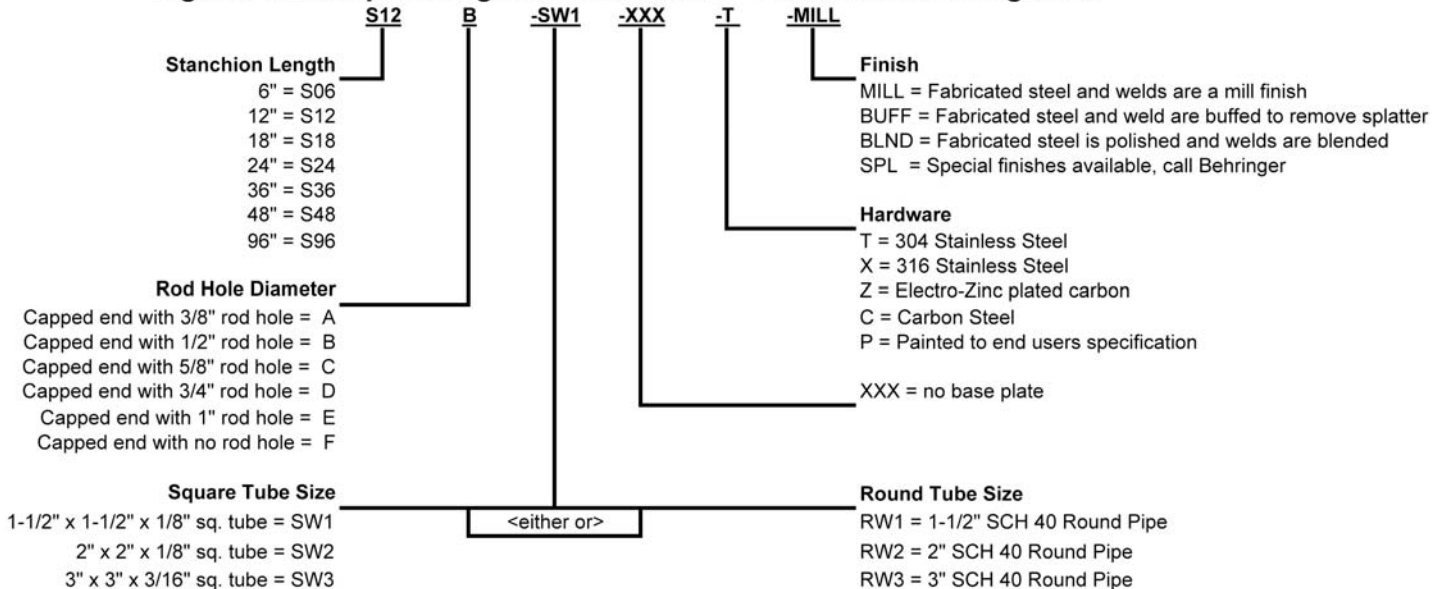

FIG. 226

TELESCOPIC ADJUSTING STANCHION - FLOOR MOUNT

One piece Floor Stand with square or round tube cut to specified length. One end of the tube has a capped end with a rod hole. The rod hole is used for telescopic adjustment of the hanger rod. The open end of the tube is welded to a base plate which can be supplied with or without anchor bolt holes. Specify the steel finish and the finish on the weld.



Features: Hole in capped end of tube allows the hanger rod to be manually adjusted for telescopic location of the tube or pipe.

Hardware: 304 Stainless Steel; 316 Stainless Steel, Carbon Steel & Electro-Zinc Plated Carbon Steel

Finish: MILL = Fabricated steel and welds are a mill finish
 BUFF = Fabricated steel and welds are buffed to remove splatter
 BLND = Fabricated steel is polished and welds are blended
 Special finishes and painted stanchions are available, call Behringer Customer Service for price and availability.

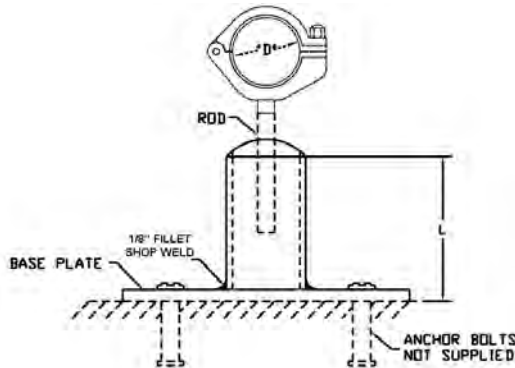

Round Stanchion Floor Mount

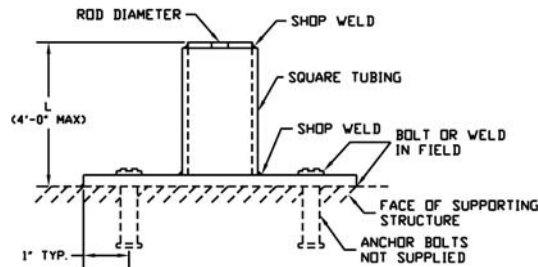

Square Stanchion Floor Mount

Base plate can be supplied without mounting holes

Fig. 226 Telescopic Floor Stand Stanchion - Part Number Configurator

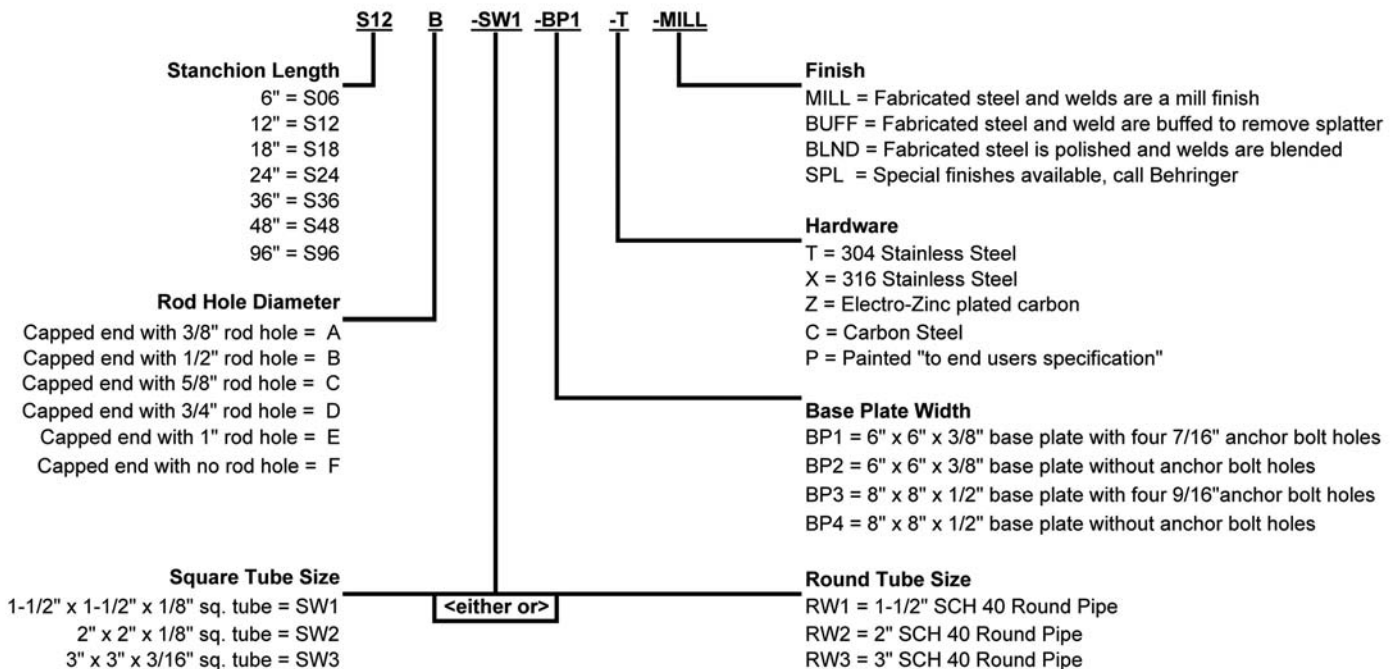

PIPE CLAMP SELECTION

Mounting / Hardware Configuration

Behringer offers an array of mounting configurations and arrangement styles for the Sanitary Smooth Bore Series supports. They can be mounted to the support structure by either welding, bolting, hanging, rail mount, strut mount or via stanchions. In addition, they can be stacked on top of each other to save on space. Please check the ordering code for available assemblies with the configuration you desire. Here are some examples of the mounting options.



Weld Mounting [STW]

Clamps are supplied with a weld plate (STW) for welding directly to the support structure. This is the most commonly used style and includes a cover plate (COP) and hex bolts (HEX).



Hang Mounting [HAP]

Clamps are supplied with a hang plate (HAP) that allows the support block to be installed at a distance from the structural member from which it is mounted. They are hung from threaded rod to the desired elevation.



Bolt Mounting [BAP]

Clamps are supplied with a Base Plate (BAP) for applications where the clamp cannot be welded into position. This is commonly used to mount to non-metallic surfaces, such as wood or drywall.



Rail Mounting [RCN, RAL]

Rail mounting makes installations of multiple lines of different group sizes an easy task. All clamps within one series can be mounted directly to a single channel using Rail Nuts (RCN) or Weld Plates (STW) in conjunction with Behringer's proprietary Mounting Rail (RAL-1).



Strut Mounting [UCN]

Clamps are supplied with Unistrut Clip Nuts (UCN) for mounting to standard Unistrut channel. The nuts adapt to any strut channel that is 1 5/8" wide. The depth of the channel is not important as the UCN clips attach with spring loaded tension to the top of the channel.



Stacking Kits [SKSB]

Stacking kits consist of a set of Clamp Halves (CLH), Stacking Bolts (STB) and a Safety Plate (SAF). A stacking kit is everything needed to take an existing clamp and add an additional level. Start by simply using the hardware from the existing clamp, remove the cover plate, clamp halves, and hex bolts and insert the stacking kit onto the bottom plate and then replace the original hardware on top. Multiple stacking kits can be added to increase the number of clamps stacked in a series.

Figure 200
Weld Plate Mount

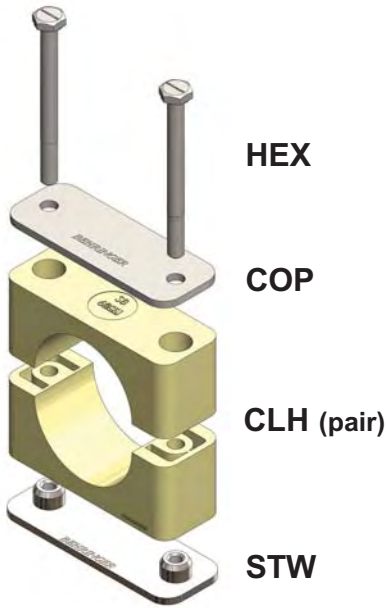

Figure 202
Base Plate Mount

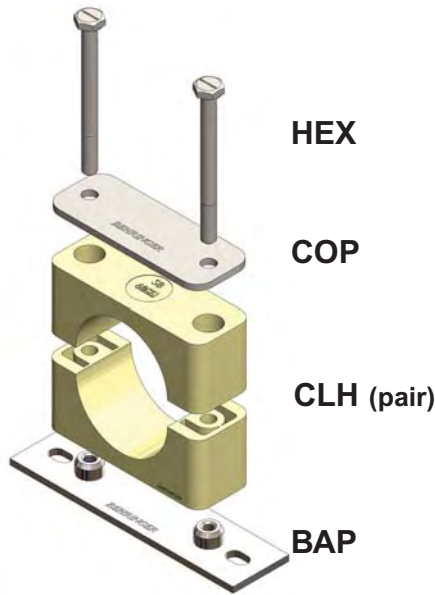

Figure 211
Unistrut Mount

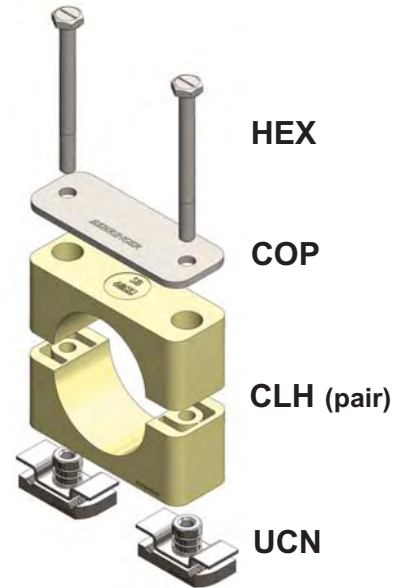
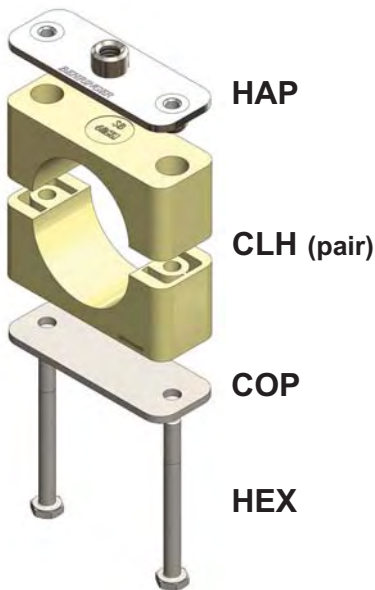

Figure 201
Hang Plate Mount



Rail Mount

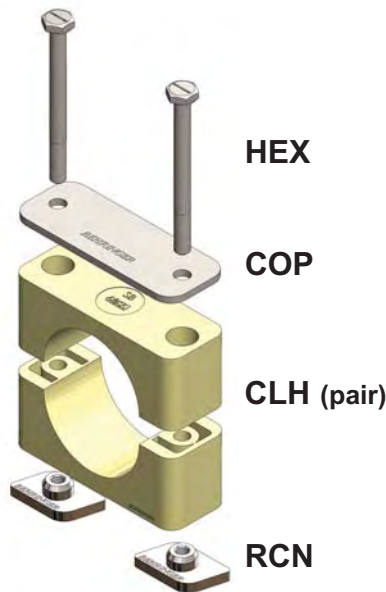
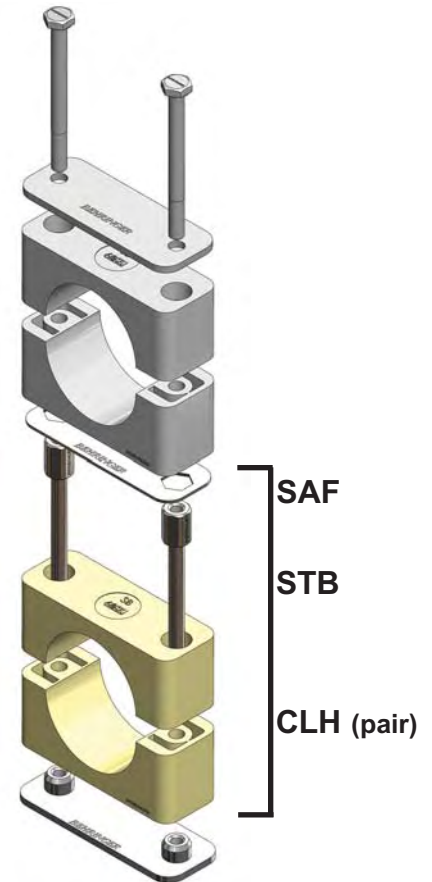

Figure 204
Stacking Kit



Key:

- | | |
|-------------------------|--------------------------|
| BAP - Base Plate | SAF - Safety Plate |
| CLH - Clamp Half (pair) | STB - Stacking Bolt |
| COP - Cover Plate | STW- Standard Weld Plate |
| HAP - Hang Plate | UCN- Unistrut Clip Nut |
| HEX - Hex Bolt | RCN- Rail Nut |

FIG. 200 BLOCK STYLE

WELD PLATE MOUNT

Size Range: 1/4" outside diameter through 8.625" outside diameter

Hardware: 304 Stainless Steel, 316 Stainless Steel, or Electro-Zinc Plated Carbon Steel

Plastic Inserts: Polypropylene (blue)
 Santoprene (beige)
 Polysulfone (black)
 HDPE (white)
 High Temp Nylon (black)
 *See page 28 for temperature ratings

Installations: Weld bottom plate to structure or supporting member, let cool before mounting plastic blocks.

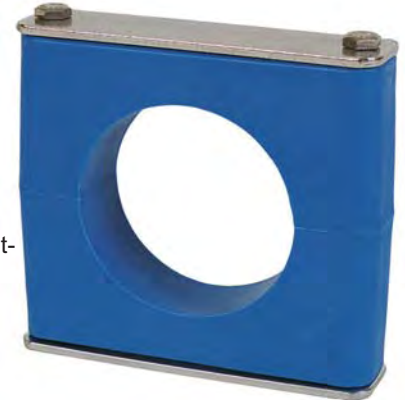

Thermal Expansion Guide: (Optional) Provides for axial expansion of the tube or pipe due to thermal expansion. One set of two per clamp (See Fig. 207 in accessories)

Thermal Expansion Guide Material: Santoprene, 1/16" insert, Black for service identification

GRP NO.	TUBE OR PIPE SIZE	"D" INCHES	W	H	Z	U	BOLT SIZE	LBS.
3	1/4 T	0.250	1.88" (48 mm)	1.38" (35 mm)	1.19" (30 mm)	0.81" (20 mm)	1/4-20	0.4 (0.18 kg)
	3/8 T	0.375						
	1/2 T	0.500						
	3/4 T	0.750						
	1/2 P	0.840						
1 T	1.000							
6	1/4 T	0.250	3.34" (85 mm)	2.63" (67 mm)	1.19" (30 mm)	1.44" (37 mm)	1/4-20	0.6 (0.27 kg)
	3/8 T	0.375						
	1/2 T	0.500						
	5/8 T	0.625						
	3/4 T	0.750						
	1/2 P	0.840						
	7/8 T	0.875						
	1 T	1.000						
	3/4 P	1.050						
	1-1/4 T	1.250						
	1 P	1.315						
1-1/2 T	1.500							
1-1/4 P	1.660							
1-1/2 P	1.900							
2 T	2.000							
7	2 T	2.000	5.00" (127 mm)	4.38" (111 mm)	1.19" (30 mm)	2.31" (59 mm)	1/4-20	1.1 (0.50 kg)
	2 P	2.375						
	2-1/2 T	2.500						
	2-1/2 P	2.875						
	3 T	3.000						
3-1/2 T -3 P	3.500							
7A	4 T	4.000	5.77" (147 mm)	4.8" (122 mm)	1.19" (33 mm)	2.54" (65 mm)	1/4-20	1.5 (0.68 kg)
8	6 T	6.000	8.88" (226 mm)	7.65" (194 mm)	1.50" (38 mm)	4.01" (102 mm)	3/8-16	4.4 (1.99 kg)
	6P	6.625						
9	8T	8.000	12.5" (318 mm)	10" (254 mm)	1.75" (44 mm)	5.38" (137 mm)	5/8 - 11	12.5 (5.7 kg)
	8P	8.625						

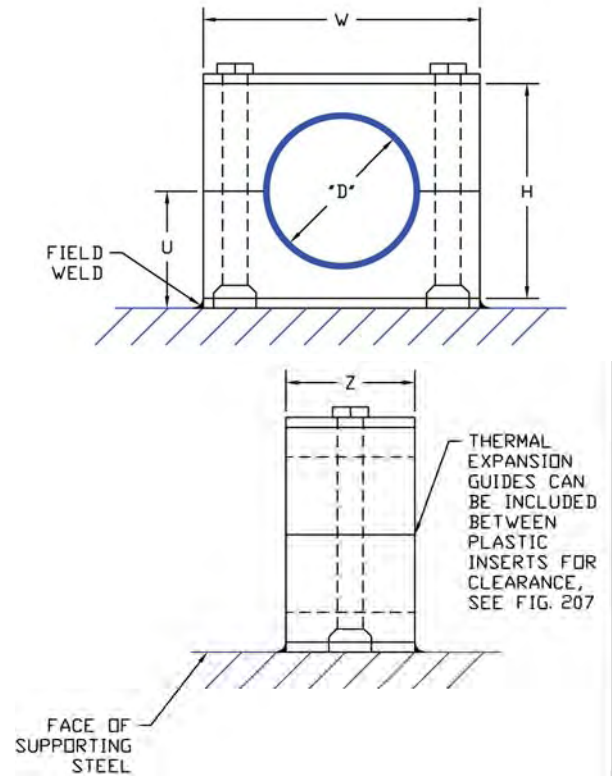
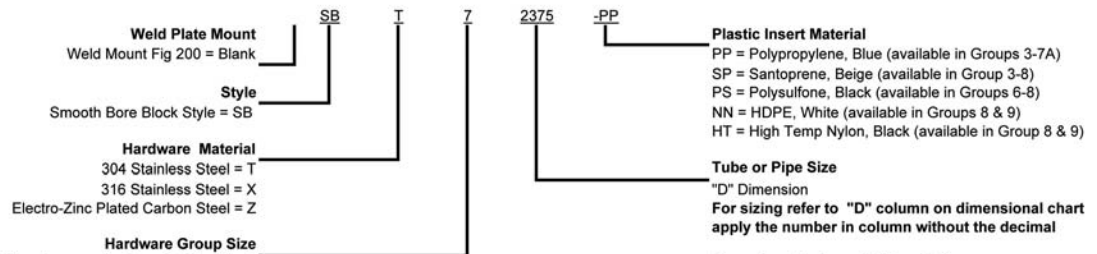

Fig 200 Smooth Bore Weld Plate Mount - Part Number Configurator



Group 3 Hardware Size Tube OD and Pipe sizes ranging from 0.25" to 1" = 3
 Group 6 Hardware Size Tube OD and Pipe sizes ranging from 0.25" to 2" = 6
 Group 7 Hardware Size Tube OD and Pipe sizes ranging from 2" to 3.50" = 7
 Group 7A Hardware Size 4" Tube OD = 7A
 Group 8 Hardware Size Tube OD and Pipe sizes ranging from 6" to 6.625" = 8
 Group 9 Hardware Size Tube OD sizes from 8" to 8.625" = 9

Examples of column "D" translation:
 1/4" Tube = 025
 3/4" Pipe = 1050
 1" Pipe = 1315
 2" Pipe = 2375
 4" Tube = 400

FIG. 201

HANG PLATE MOUNT

Size Range: 1/4" outside diameter through 6.625" diameter

Hardware: 304 Stainless Steel, 316 Stainless Steel, or Electro-Zinc Plated Carbon Steel

Plastic Inserts: Polypropylene (blue)
 Santoprene (beige)
 Polysulfone (black)
 HDPE (white)
 High Temp Nylon (black)
 *See page 28 for temperature ratings

Installations: Hang from threaded rod to desired elevation

Thermal Expansion Guide: (Optional) Provides for axial expansion of the tube or pipe due to thermal expansion. One set of two per clamp (See Fig. 207 in accessories)

Thermal Expansion Guide Material: Santoprene, 1/16" insert, Black for service identification



GRP NO.	TUBE OR PIPE SIZE	"D" INCHES	W	H	Z	U	BOLT SIZE	HANG NUT	LBS.
3	1/4 T	0.250	1.88" (48 mm)	1.38" (35 mm)	1.19" (30 mm)	0.81" (20 mm)	1/4-20	3/8-16	0.3 (0.14 kg)
	3/8 T	0.375							
	1/2 T	0.500							
	3/4 T	0.750							
	1/2 P	0.840							
1 T	1.000								
6	1/4 T	0.250	3.34" (85 mm)	2.63" (67 mm)	1.19" (30 mm)	1.44" (37 mm)	1/4-20	3/8-16	0.5 (0.23 kg)
	3/8 T	0.375							
	1/2 T	0.500							
	5/8 T	0.625							
	3/4 T	0.750							
	1/2 P	0.840							
	7/8 T	0.875							
	1 T	1.000							
	3/4 P	1.050							
	1-1/4 T	1.250							
	1 P	1.315							
	1-1/2 T	1.500							
1-1/4 P	1.660								
1-1/2 P	1.900								
2 T	2.000								
7	2 T	2.000	5.00" (127 mm)	4.38" (111 mm)	1.19" (30 mm)	2.31" (59 mm)	1/4-20	3/8-16	1.00 (0.45 kg)
	2 P	2.375							
	2-1/2 T	2.500							
	2-1/2 P	2.875							
	3 T	3.000							
	3-1/2 T-3 P	3.500							
7A	4 T	4.000	5.77" (147 mm)	4.8" (122 mm)	1.19" (33 mm)	2.54" (65 mm)	1/4-20	3/8-16*	1.30 (0.59 kg)
8	6 T	6.000	8.88" (226 mm)	7.65" (194 mm)	1.50" (38 mm)	4.01" (102 mm)	3/8-16	5/8-11	4.00 (1.8 kg)
	6P	6.625							

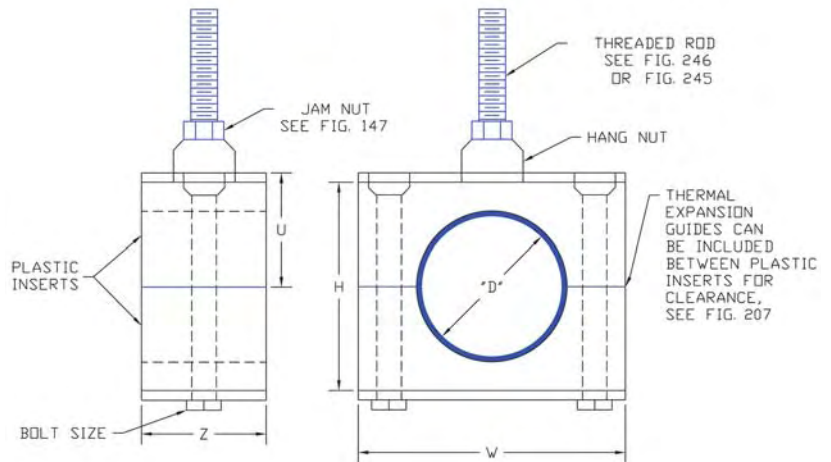

* Also available with a 1/2 - 13 thread

Fig 201 Smooth Bore Hang Mount - Part Number Configurator

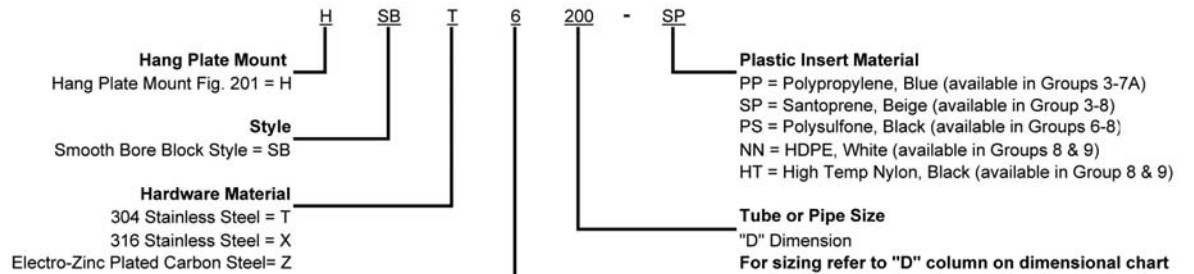

- Group 3 Hardware Size Tube OD and Pipe sizes ranging from 0.25" to 1" = 3
- Group 6 Hardware Size Tube OD and Pipe sizes ranging from 0.25" to 2" = 6
- Group 7 Hardware Size Tube OD and Pipe sizes ranging from 2" to 3.50" = 7
- Group 7A Hardware Size 4" Tube OD = 7A
- Group 8 Hardware Size Tube OD and Pipe sizes ranging from 6" to 6.625" = 8

- Examples of column "D" translation:**
- 1/4" Tube = 025
 - 3/4" Pipe = 1050
 - 1" Pipe = 1315
 - 2" Pipe = 2375
 - 4" Tube = 400

FIG. 202

BASE PLATE MOUNT

Size Range: 1/4" outside diameter through 6.625" outside diameter

Hardware: 304 Stainless Steel, 316 Stainless Steel, or Electro-Zinc Plated Carbon Steel

Plastic Insert: Polypropylene (blue)
 Santoprene (beige)
 Polysulfone (black)
 HDPE (white)
 High Temp Nylon (black)
 *See page 28 for temperature ratings



Installation: Locate bolt holes in mounting structure and either tap into structure or use 1/4-20 bolt and nut to secure

Thermal Expansion Guide: (Optional) Provides for axial expansion of the tube or pipe due to thermal expansion. One set of two per clamp (See Fig. 207 in accessories)

Thermal Expansion Guide Material: Santoprene, 1/16" insert, Black for service identification

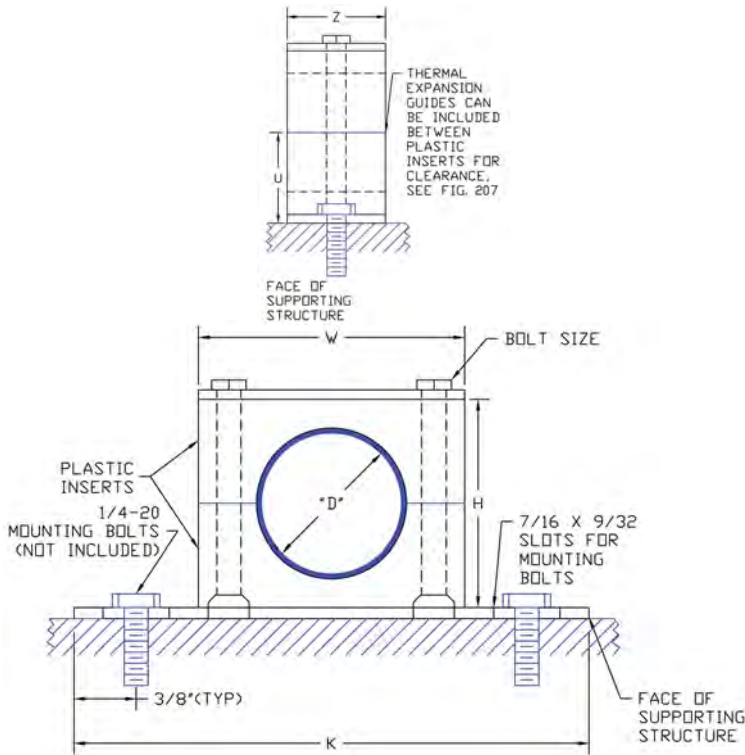

GROUP NO.	TUBE OR PIPE SIZE	"D" INCHES	INCHES					BOLT SIZE	LBS.
			W	H	Z	U	K		
3	1/4 T	0.250	1.88" (48 mm)	1.38" (35 mm)	1.19" (30 mm)	0.81" (20 mm)	3.50" (89 mm)	1/4-20	0.4 (0.18 kg)
	3/8 T	0.375							
	1/2 T	0.500							
	3/4 T	0.750							
	1/2 P	0.840							
	1 T	1.000							
6	1/4 T	0.250	3.34" (85 mm)	2.63" (67 mm)	1.19" (30 mm)	1.44" (37 mm)	4.50" (114 mm)	1/4-20	0.6 (0.27 kg)
	3/8 T	0.375							
	1/2 T	0.500							
	5/8 T	0.625							
	3/4 T	0.750							
	1/2 P	0.840							
	7/8 T	0.875							
	1 T	1.000							
	3/4 P	1.050							
	1-1/4 T	1.250							
	1 P	1.315							
	1-1/2 T	1.500							
7	1-1/4 P	1.660	5.00" (127 mm)	4.38" (111 mm)	1.19" (30 mm)	2.31" (59 mm)	6.50" (165 mm)	1/4-20	1.1 (0.50 kg)
	1-1/2 P	1.900							
	2 T	2.000							
	2 P	2.000							
	2 P	2.375							
7A	2-1/2 T	2.500	5.00" (127 mm)	4.38" (111 mm)	1.19" (30 mm)	2.31" (59 mm)	6.50" (165 mm)	1/4-20	1.1 (0.50 kg)
	2-1/2 P	2.875							
8	3 T	3.000	5.00" (127 mm)	4.38" (111 mm)	1.19" (30 mm)	2.31" (59 mm)	6.50" (165 mm)	1/4-20	1.1 (0.50 kg)
	3-1/2 T - 3 P	3.500							
	4 T	4.000							
8	6 T	6.000	8.88" (226 mm)	7.65" (194 mm)	1.50" (38 mm)	4.01" (102 mm)	11.25" (286 mm)	3/8-16	4.4 (1.97 kg)
	6P	6.625							

Fig 202 Smooth Bore Base Plate Mount - Part Number Configurator

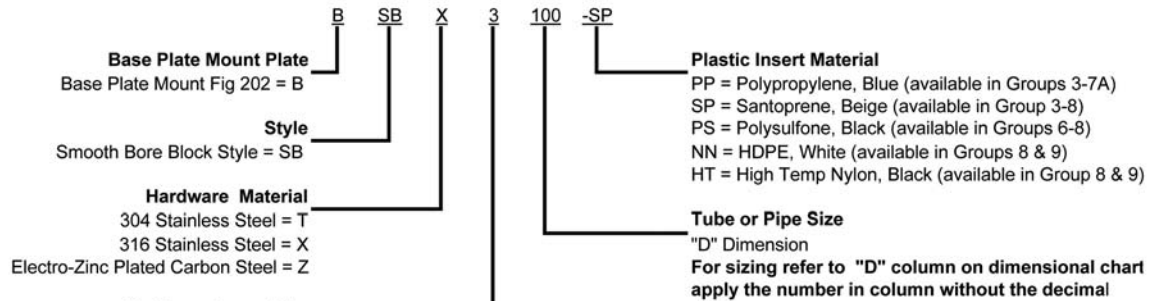

Examples of column "D" translation:

- 1/4" Tube = 025
- 3/4" Pipe = 1050
- 1" Pipe = 1315
- 2" Pipe = 2375
- 4" Tube = 400

FIG. 203

RAL-1 RAIL MOUNTING

Size Range: Rail Accomodates Clamps from 1/4" through 4" tube

Hardware: 304 Stainless Steel; 316 Stainless Steel; Electro-Zinc Plated Carbon Steel

Installations: Weld Rail (RAL-1) to structure or supporting member. Slide clamp weld plate into rail, locate proper position and assemble clamp. Tightening hex bolts of clamp will lock clamp into position.

***See Alternate Mounting Option below**

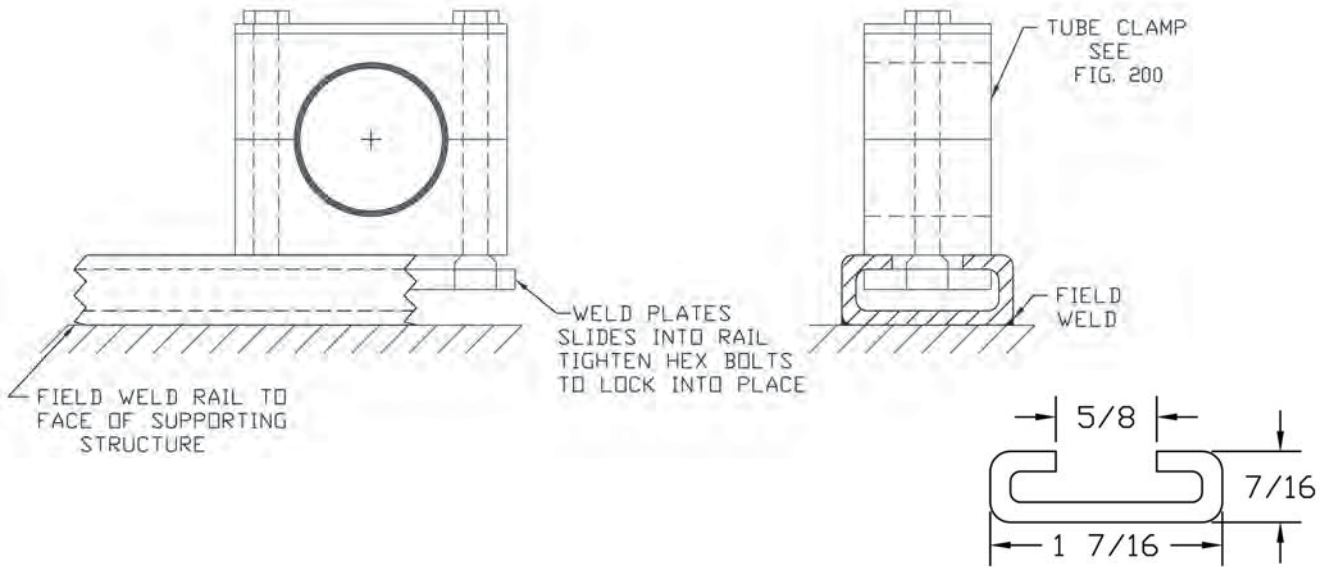
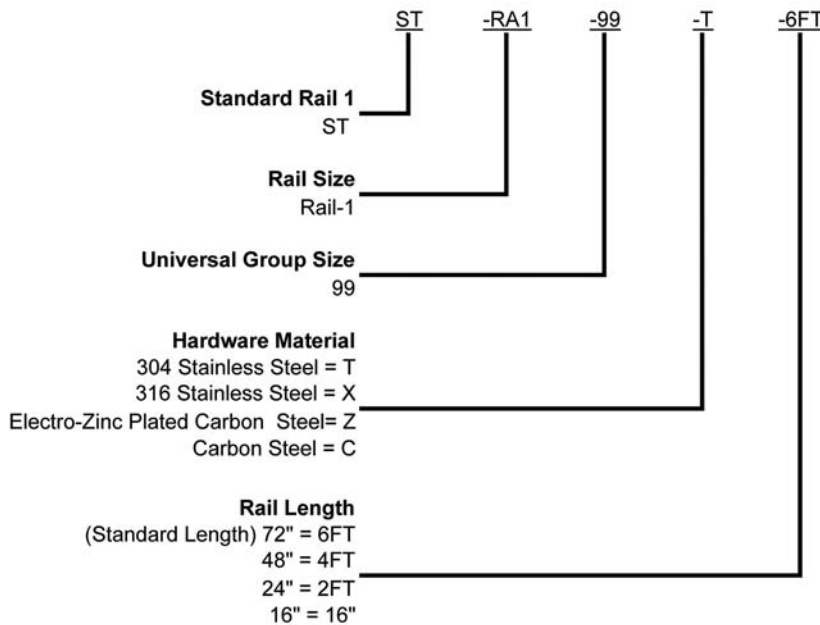
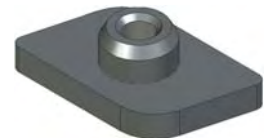

Fig 203 Rail Mounting (RAL-1) - Part Number Configurator



***Alternate Mounting Option**



RCN-1

Rail Nut (RCN-1) may also be used when mounting to Behringer's proprietary mounting rail (RAL-1)

FIG. 204

STACKING KIT

Size Range: Any double combination of sizes 1/4" outside diameter through 3.5" outside diameter

Hardware: 304 Stainless Steel, 316 Stainless Steel, or Electro-Zinc Plated Carbon Steel

Plastic Inserts: Polypropylene (blue)
Santoprene (beige)
Polysulfone (black)
*See page 28 for temperature ratings

Thermal Expansion Guide: (Optional) Provides for axial expansion of the tube or pipe due to thermal expansion. One set of two per clamp (See Fig. 207 in accessories).

Thermal Expansion Guide Material: Santoprene, 1/16" insert, Black for service identification



*****NOTE:** This is sold as a modular component ONLY. Must order Fig. 200, 201 or 202 as a bottom assembly in addition to each stacking kit.

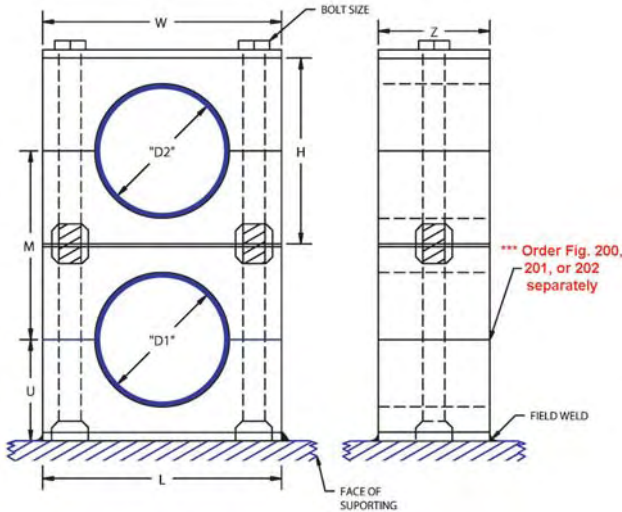

GRP NO.	TUBE OR PIPE SIZE	"D" INCHES	W	H	Z	U	L	M	BOLT SIZE
3	1/4 T	0.250	1.88 (48 mm)	1.38" (35 mm)	1.19" (30 mm)	0.81" (20 mm)	1.91 (49 mm)	1.44" (37 mm)	1/4-20
	3/8 T	0.375							
	1/2 T	0.500							
	3/4 T	0.750							
	1/2 P	0.840							
1 T	1.000								
6	1/4 T	0.250	3.34" (85 mm)	2.63" (67 mm)	1.19" (30 mm)	1.44" (37 mm)	3.37 (86 mm)	2.69 (68 mm)	1/4-20
	3/8 T	0.375							
	1/2 T	0.500							
	5/8 T	0.625							
	3/4 T	0.750							
	1/2 P	0.840							
	7/8 T	0.875							
	1 T	1.000							
	3/4 P	1.050							
	1-1/4 T	1.250							
	1 P	1.315							
	1-1/2 T	1.500							
1-1/4 P	1.660								
1-1/2 P	1.900								
2 T	2.000								
7	2 T	2.000	5.00" (127 mm)	4.38" (111 mm)	1.19" (30 mm)	2.31" (59 mm)	4.41" (112 mm)	4.44" (113 mm)	1/4-20
	2 P	2.375							
	2-1/2 T	2.500							
	2-1/2 P	2.875							
	3 T	3.000							
3-1/2 T-3 P	3.500								

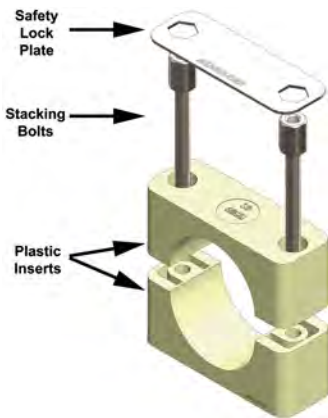

Fig 204 Smooth Bore Stacking Kit - Part Number Configurator

Stacking Kit Components Fig 204 = SK

Style Smooth Bore Block Style = SB

Hardware Material
304 Stainless Steel = T
Stainless Steel = X
Electro-Zinc Plated Carbon Steel = Z

Hardware Group Size
Group 3 Hardware Size Tube OD and Pipe sizes ranging from 0.25" to 1" = 3
Group 6 Hardware Size Tube OD and Pipe sizes ranging from 0.25" to 2" = 6
Group 7 Hardware Size Tube OD and Pipe sizes ranging from 2" to 3.50" = 7

Plastic Insert Material
PP = Polypropylene, Blue (available in Groups 3-7A)
SP = Santoprene, Beige (available in Group 3-8)
PS = Polysulfone, Black (available in Groups 6-8)

Tube or Pipe Size
"D" Dimension
For sizing refer to "D" column on dimensional chart apply the number in column without the decimal

Examples of column "D" translation:
1/4" Tube = 025
3/4" Pipe = 1050
1" Pipe = 1315
2" Pipe = 2375

FIG. 211

UNISTRUT MOUNT CLAMP

Size Range: 1/4" outside diameter through 4" outside diameter.

Hardware: 304 Stainless Steel, 316 Stainless Steel, or Electro-Zinc Plated Carbon Steel

Plastic Inserts: Polypropylene (blue)
 Santoprene (tan)
 Polysulfone (black)
 *See page 28 for temperature ratings

Installations: After unistrut rail position has been established, position 2 unistrut rail nuts in channel where desired to accept plastic inserts. Place pipe or tube in clamp perpendicular to unistrut channel. Torque down on clamp bolts to lock assembly in place.

Thermal Expansion Guide: (Optional) Provides for axial expansion of the tube or pipe due to thermal expansion. One set of two per clamp (See Fig. 207 in accessories).

Thermal Expansion Guide Material: Santoprene, 1/16" insert, Black for service identification



GROUP NO.	TUBE OR PIPE SIZE	"D" INCHES	INCHES				LBS.
			W	H	Z	U	
3	1/4 T	0.250	1.88 (48 mm)	1.38 (35 mm)	1.19 (30 mm)	.75 (19 mm)	0.4 (0.18 kg)
	3/8 T	0.375					
	1/2 T	0.500					
	3/4 T	0.750					
	1/2 P	0.840					
	1 T	1.000					
6	1/4 T	0.250	3.34 (85 mm)	2.63 (67 mm)	1.19 (30 mm)	1.38 (35 mm)	0.6 (0.27 kg)
	3/8 T	0.375					
	1/2 T	0.500					
	5/8 T	0.625					
	3/4 T	0.750					
	1/2 P	0.840					
	7/8 T	0.875					
	1 T	1.000					
	3/4 P	1.050					
	1-1/4 T	1.250					
	1 P	1.315					
	1-1/2 T	1.500					
	1-1/4 P	1.660					
	1-1/2 P	1.900					
7	2 T	2.000	5.00 (127 mm)	4.38 (111 mm)	1.19 (30 mm)	2.25 (57 mm)	1.1 (0.50 kg)
	2 P	2.375					
	2-1/2 T	2.500					
	2-1/2 P	2.875					
	3 T	3.000					
	3-1/2 T - 3 P	3.500					
7A	4 T	4.000	5.77 (147 mm)	4.8 (122 mm)	1.19 (30 mm)	2.48 (62 mm)	1.5 (0.68 kg)

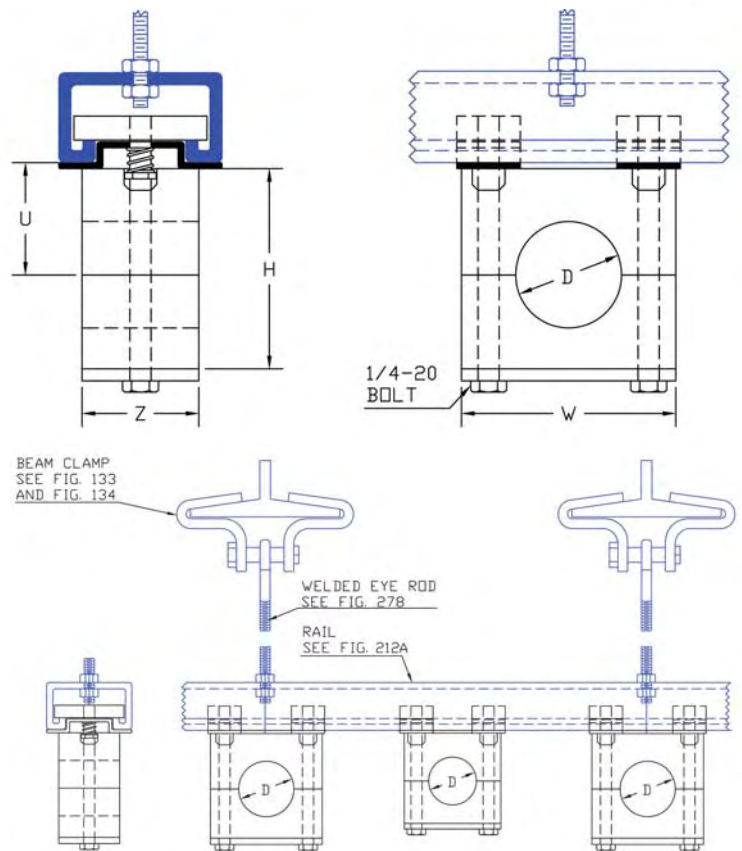
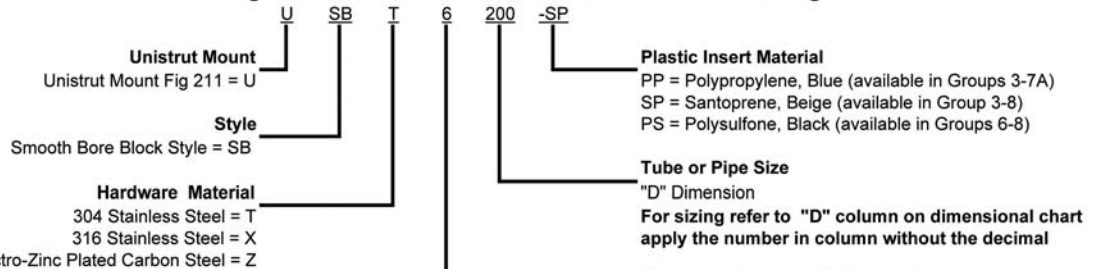

Fig 211 Smooth Bore Unistrut Mount - Part Number Configurator



Hardware Group Size
 Group 3 Hardware Size Tube OD and Pipe sizes ranging from 0.25" to 1" = 3
 Group 6 Hardware Size Tube OD and Pipe sizes ranging from 0.25" to 2" = 6
 Group 7 Hardware Size Tube OD and Pipe sizes ranging from 2" to 3.50" = 7
 Group 7A Hardware Size 4" Tube OD = 7A

Examples of column "D" translation:

- 1/4" Tube = 025
- 3/4" Pipe = 1050
- 1" Pipe = 1315
- 2" Pipe = 2375
- 4" Tube = 400

FIG. 221

ROD MOUNT

Size Range: 1/4" outside diameter through 6.625" outside diameter

Hardware: 304 Stainless Steel, 316 Stainless Steel, or Electro-Zinc Plated Carbon Steel

Plastic Inserts: Polypropylene (blue)
 Santoprene (beige)
 Polysulfone (black)
 HDPE (white)
 High Temp Nylon (black)
 *See page 28 for temperature ratings

Installations: Cut bar in field to proper length. Field weld hang or floor mount bar to support structure. Fig 221 can also be used in combination with the figure 225 or 226 stanchions. This combination will allow the support to be adjusted telescopically to the tube or pipe elevation. Call customer service for the price and availability of special rod lengths.



Thermal Expansion Guide: (Optional) Provides for axial expansion of the tube or pipe due to thermal expansion. One set of two per clamp. (See Fig. 207 in accessories).

Thermal Expansion Guide Material: Santoprene, 1/16" insert, Black for service identification

GRP NO.	TUBE OR PIPE SIZE	"D" INCHES	W	Z	U	BOLT SIZE	"A" ROD DIA
3	1/4 T	0.250	1.88" (48 mm)	1.19" (30 mm)	0.81" (20 mm)	1/4-20	0.5" (12.7 mm)
	3/8 T	0.375					
	1/2 T	0.500					
	3/4 T	0.750					
	1/2 P	0.840					
	1 T	1.000					
6	1/4 T	0.250	3.34" (85 mm)	1.19" (30 mm)	1.44" (37 mm)	1/4-20	0.5" (12.7 mm)
	3/8 T	0.375					
	1/2 T	0.500					
	5/8 T	0.625					
	3/4 T	0.750					
	1/2 P	0.840					
	7/8 T	0.875					
	1 T	1.000					
	3/4 P	1.050					
	1-1/4 T	1.250					
	1 P	1.315					
	1-1/2 T	1.500					
	1-1/4 P	1.660					
	1-1/2 P	1.900					
7	2 T	2.000	5.00" (127 mm)	1.19" (30 mm)	2.31" (59 mm)	1/4-20	0.75" (19 mm)
	2 P	2.375					
	2-1/2 T	2.500					
	2-1/2 P	2.875					
	3 T	3.000					
	3-1/2 T -3 P	3.500					
7A	4 T	4.000	5.77" (147 mm)	1.19" (33 mm)	2.54" (65 mm)	1/4-20	0.75" (19 mm)
8	6 T	6.000	8.88" (226 mm)	1.50" (38 mm)	4.01" (102 mm)	3/8-16	1.00" (25.4 mm)
	6 P	6.625					

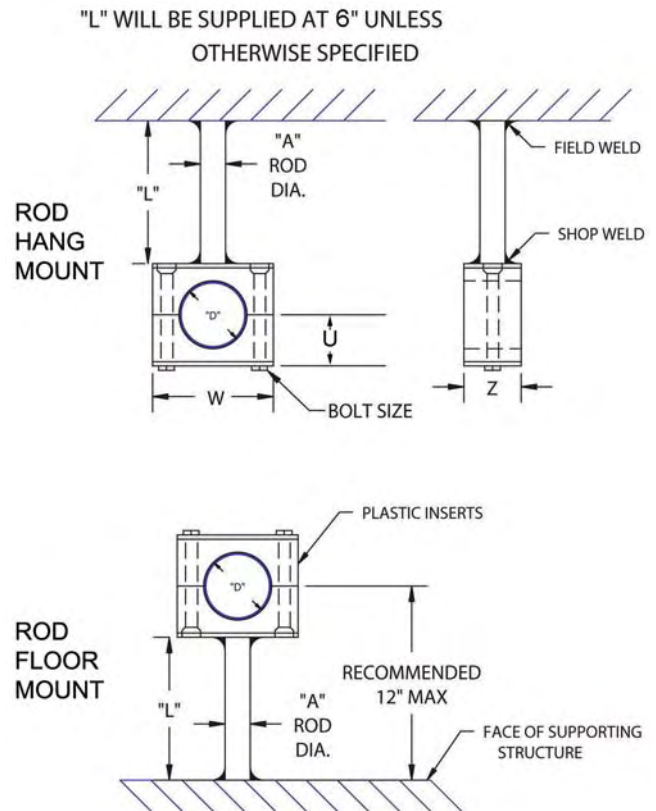
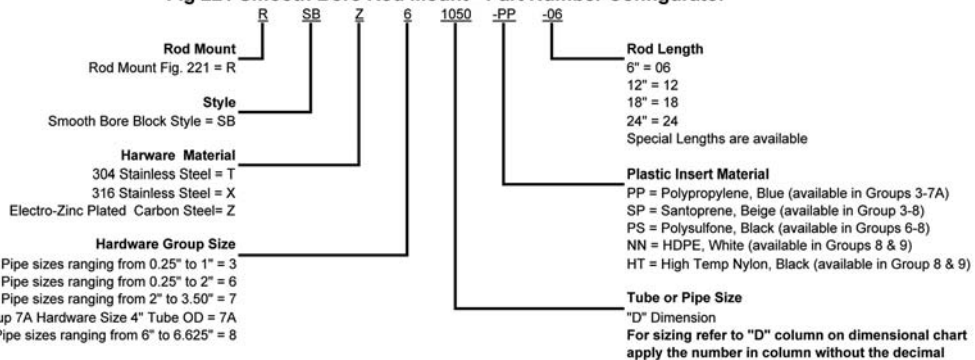

Fig 221 Smooth Bore Rod Mount - Part Number Configurator



TECHNICAL APPENDIX

Proper Slope for Drainability

Process piping must be installed to achieve:

- Continuous slope for drainability—offset any deflection present with slope.
- Adequate spacing of supports to avoid pooling of liquids
- Minimum slope per ASME BPE Standard:
 - Table SD-2.4.3.1-1 Slope Designations for Gravity-Drained Lines
 - GSD1 $\frac{1}{16}$ "/ft. minimum (5mm/m)
 - GSD2 $\frac{1}{8}$ "/ft. minimum (10mm/m)
 - (min. recommended by ASME for product-contact lines)
 - GSD3 $\frac{1}{4}$ "/ft. minimum (20mm/m)
 - GSD0 Line slope not required
- Slope measurements should be taken with a calibrated digital level or protractor per ASME BPE Non-Mandatory Appendix C
- Added support in proximity to any concentrated loads
- Supports at each change of direction
- Corrosion resistance
- Materials compatible with the chemical, thermal, and physical performance requirements of each application

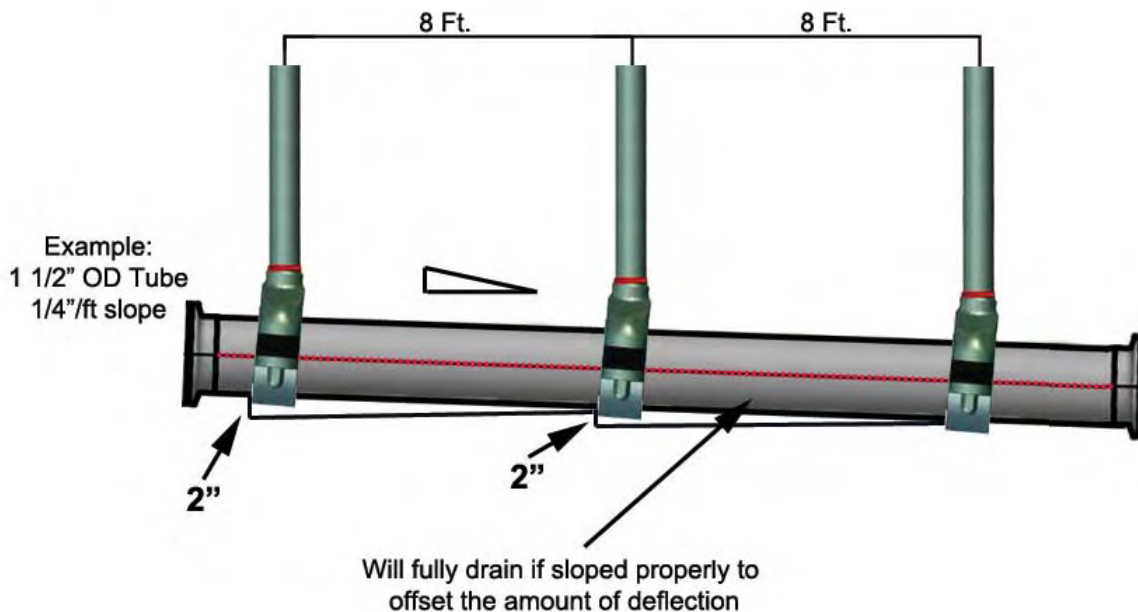
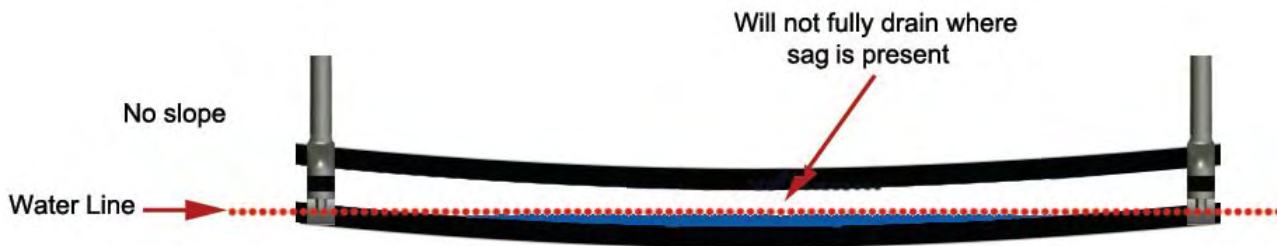

TECHNICAL APPENDIX

Recommended Mounting Practices

Bends



Behringer recommends that supports and hangers be installed in close proximity to each change in direction of piping, with consideration of pipe movement due to thermal expansion and use of anchor and guide inserts to facilitate intended pipe movements.

Concentrated Loads

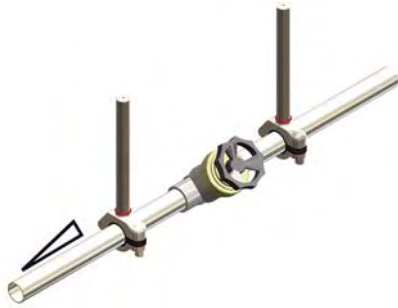

Behringer recommends that supports and hangers be installed as close as possible to any concentrated loads, such as valves, instrumentation, and other process components. It may be necessary to install on both sides of certain loads to reduce deflection and ensure proper continuous slope for drainability.

Thermal Expansion

- Anchoring systems should be designed to accommodate piping motion including thermal expansion.
- Proper selection and positioning of anchors and guides to facilitate thermal cycling of the piping with out causing structural damage or cause process components to misalign at mechanical joints.
- **Anchor** - An anchor is a rigid device used to prevent all pipe displacement at the point of application. Anchors are used to fix selected points on a piping system in order to control forces, moments, and movement in each section of the total pipe run.
- **Guide** - A guide is a device used to permit pipe movement in a predetermined direction while preventing undesirable movement in other directions. Guides are used to control piping movement, provide lateral pipe stability, control sway, and ensure proper alignment at expansion joints and loops. The guide allows free axial movement of the pipe/tube while maintaining proper alignment and elevation for drainability.
- Enlarging the ID dimension of the CH Series Polysulfone insert by .040" (Groups 1-5) and 0.050" (Groups 6-9) turns a gripping support "Anchor" into a "Guide". Behringer stocks both anchor and guide inserts for OD tube, pipe, and copper tube sizes. See part number configuration for more information. Guide inserts are also available for the Smooth Bore Series (See Fig. 207 in accessories)



MATERIAL PROPERTIES, TECHNICAL DATA

Smooth Bore Inserts

General Information			Thermal Properties	
Plastic Insert Material	Part # Code	Color	Intermittent Exposure	Continuous Exposure
Polypropylene	PP	Blue	-22° to + 212°F (-30° to + 102°C)	-22° to + 194°F (-30° to + 90° C)
Santoprene	SP	Beige	-40° to + 302°F (-40° to + 150° C)	-40° to + 275°F (-40° to + 135°C)
Polysulfone	PS	Black	-50° to + 320°F (-45° to + 160°C)	-50° to + 320°F (-45° to + 160°C)
Zeotherm	ZT	Black	-40° to + 350°F (-40° to + 175°C)	-40° to + 300°F (-40° to + 150°C)
High Density Polyethylene*	NN	White	-58° to + 180°F (-50° to + 82°C)	-58° to + 175°F (-50° to + 79°C)
High Temp Nylon*	HT	Black	-40° to + 350°F (-40° to + 177°C)	-40° to + 260°F (-40° to + 127°C)

* NN & HT inserts available in group 8 & 9 sizes only

CH Series Inserts

General Information			Thermal Properties	
Plastic Insert Material	Part # Code	Color	Intermittent Exposure	Continuous Exposure
Polysulfone	PS	Black	-50° to + 320°F (-45° to + 160°C)	-50° to + 320°F (-45° to + 160°C)
Polysulfone	PG	Grey	-50° to + 320°F (-45° to + 160°C)	-50° to + 320°F (-45° to + 160°C)

Chemical Properties	Resistant to a wide range of chemicals. Please contact Behringer for Product Data Sheets.
Mechanical Properties	

Metal Parts

- Surface finishing

In addition to the standard surface finish, alternative finishes are available on request

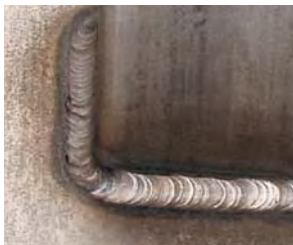

Mill Finish



Brushed



Blended Weld

SLOPE CONVERSION CHART, SHEAR FORCE DIAGRAM

Table 1 - Slope by Percentage (%) (most accurate)			Table 2 - Slope by Degrees (°) (second accurate)			Table 3 - Slope by inches/foot (least accurate)			
Percent (%)	Degrees (°)	inches/foot	Degrees (°)	Percent (%)	inches/foot	inches/foot	decimal eq	Percent (%)	Degrees (°)
0.1	0.057	0.012	0.1	0.175	0.021	1/64	0.016	0.130	0.075
0.2	0.115	0.024	0.2	0.349	0.042	1/32	0.031	0.260	0.149
0.3	0.172	0.036	0.3	0.524	0.063	3/64	0.047	0.391	0.224
0.4	0.229	0.048	0.4	0.698	0.084	1/16	0.063	0.521	0.298
0.5	0.286	0.060	0.5	0.873	0.105	5/64	0.078	0.651	0.373
0.6	0.344	0.072	0.6	1.047	0.126	3/32	0.094	0.781	0.448
0.7	0.401	0.084	0.7	1.222	0.147	7/64	0.109	0.911	0.522
0.8	0.458	0.096	0.8	1.396	0.168	1/8	0.125	1.042	0.597
0.9	0.516	0.108	0.9	1.571	0.189	9/64	0.141	1.172	0.671
1.0	0.573	0.120	1.0	1.746	0.209	5/32	0.156	1.302	0.746
1.1	0.630	0.132	1.1	1.925	0.231	11/64	0.172	1.432	0.821
1.2	0.688	0.144	1.2	2.100	0.252	3/16	0.188	1.563	0.895
1.3	0.745	0.156	1.3	2.275	0.273	13/64	0.203	1.693	0.970
1.4	0.802	0.168	1.4	2.450	0.294	7/32	0.219	1.823	1.044
1.5	0.859	0.180	1.5	2.625	0.315	15/64	0.234	1.953	1.119
1.6	0.917	0.192	1.6	2.800	0.336	1/4	0.250	2.083	1.193
1.7	0.974	0.204	1.7	2.975	0.357	5/16	0.313	2.604	1.492
1.8	1.031	0.216	1.8	3.150	0.378	3/8	0.375	3.125	1.790
1.9	1.088	0.228	1.9	3.325	0.399	7/16	0.438	3.646	2.088
2.0	1.146	0.240	2.0	3.492	0.419	1/2	0.500	4.167	2.386

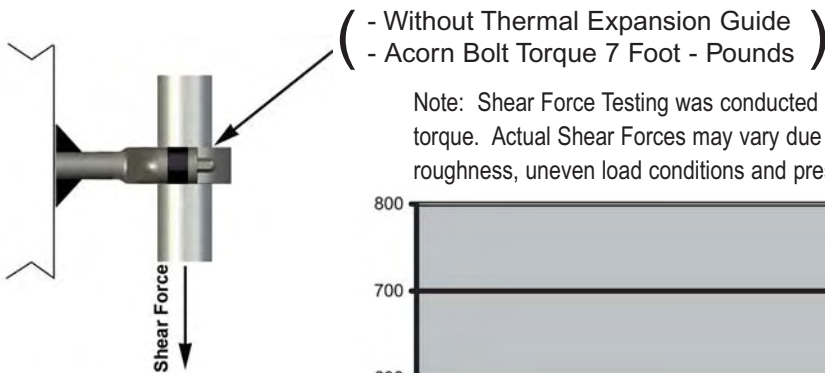

Note: Shear Force Testing was conducted under controlled conditions and with manufacturers recommended bolt torque. Actual Shear Forces may vary due to specific process conditions such as temperature, tube surface roughness, uneven load conditions and presence of line shock and/or vibration.

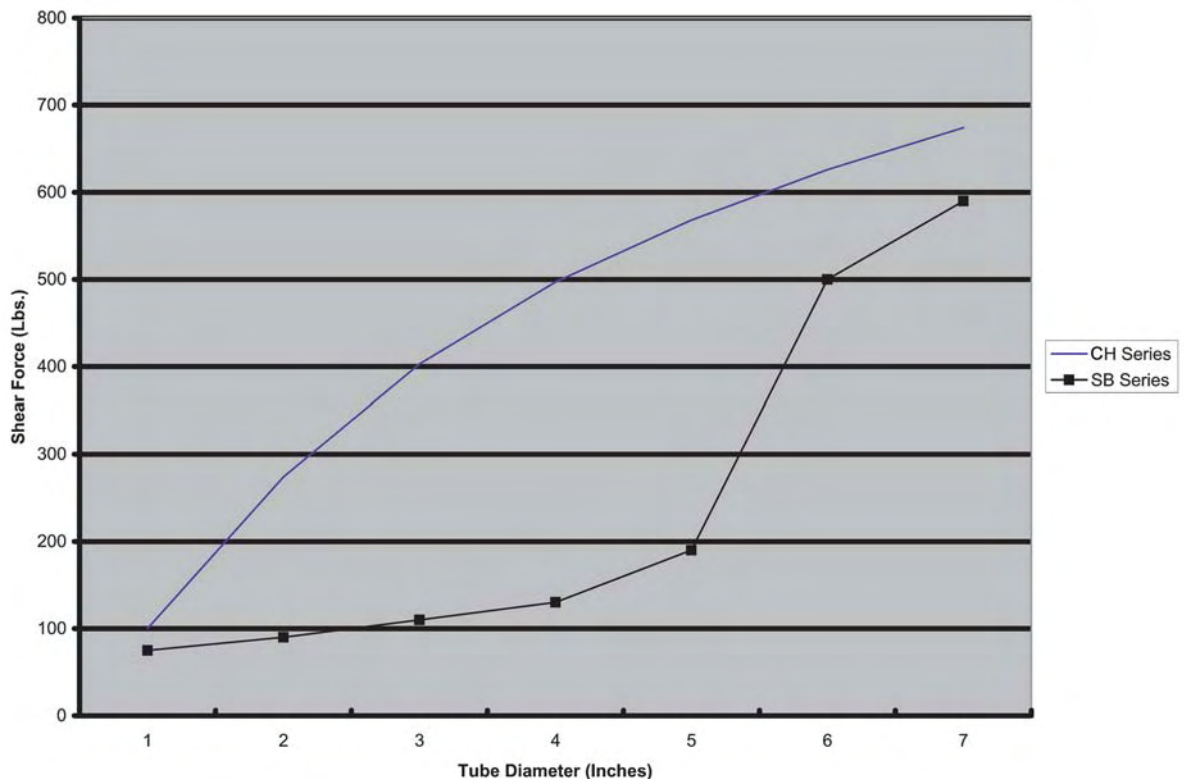

SPACING OF HANGERS

Hangers and/or supports shall be spaced as far apart as economically possible, with due consideration to assure that the sag of the pipe between supports is within limits that will permit drainage and also avoid excessive bending stresses from concentrated loads such as valves and in-line equipment. Contractor shall use the maximum recommended spacing between pipe support specified below. Spacing indicated below may differ from that listed in MSS SP- 69. Additional hangers may be necessary to adequately support concentrated loads such as valves, flanges, or instruments.

STEEL PIPE HANGER SPACING:

PIPE SIZE (IN)	MAXIMUM SPACING (FT)
1/2" & 3/4"	6
1" & 1-1/4"	8
1-1/2" & 2"	10
3"	12
4" -16"	16

COPPER TUBING HANGER SPACING (includes schedule 10 pipe):

TUBING SIZE (IN)	MAXIMUM SPACING (FT)
3/8" - 3/4"	6
1" - 1-1/4"	8
1- 1/2" - 3"	10
4" - 8"	12

STAINLESS STEEL SANITARY TUBING HANGER SPACING:

TUBING SIZE (IN)	MAXIMUM SPACING (FT)
1/2" - 3/4"	6
1" - 1-1/2"	8
2" - 3"	10
4" - 6"	12

PLASTIC PIPING:

Support in accordance with manufacturer's recommendations.

Also available from Behringer Corporation Industrial Pipe Clamps

Standard Series Pipe Clamps



Range: ¼" OD to 4" OD
Pressure: 2,000 psi max.

Heavy Series Pipe Clamps



Range: ¼" OD to 8" Pipe
Pressure: 5,000 psi max. (Single plate)
10,000 psi max. (Double plate)

Twin Series Pipe Clamps



Range: ¼" OD to 1.66" OD
Pressure: 1,500 psi max.

Heavy 4 Series Pipe Clamps



Range: 8" Pipe to 30" Pipe
Pressure: 5,000 psi max. (Single plate)
10,000 psi max. (Double plate)

BEHRINGER®

For additional information visit our Sanitary Section on our website:
www.behringersystems.com/HygienicTubeHangers-Supports.html

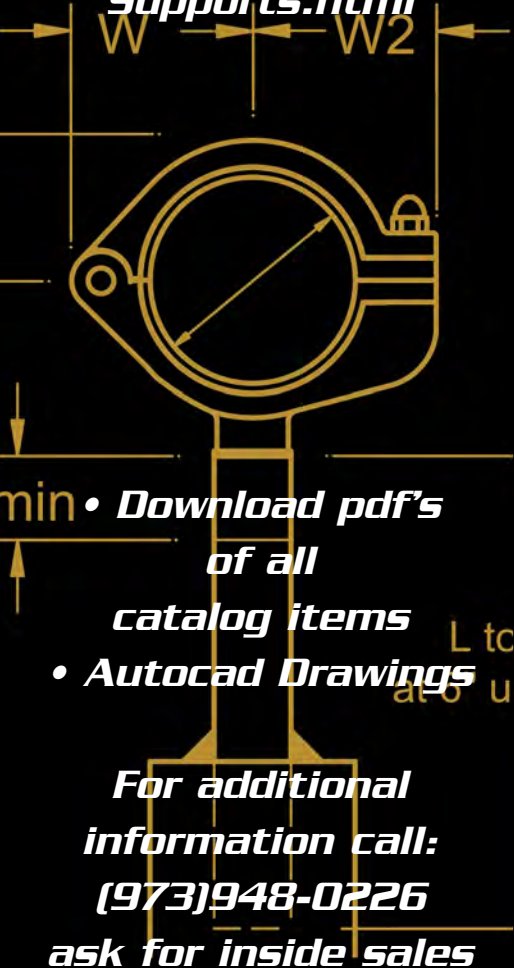
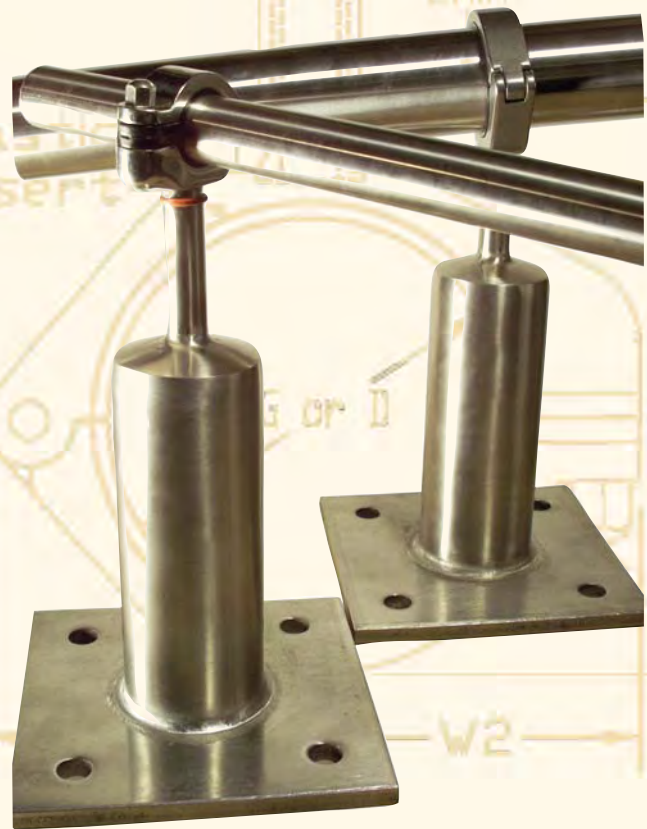

- Download pdf's of all catalog items
- Autocad Drawings

For additional information call:
(973)948-0226
ask for inside sales

BEHRINGER®

17 Ridge Road
Branchville, NJ 07826

Phone: 973-948-0226

Fax: 973-948-2562

www.behringersystems.com

Email: cserv@behringer-systems.com

Your Local Stocking Distributor:



Catalog #CHSAND412